



SIXTY82™



The Innovators

The New Original

Give people the tools, and they will build incredible stuff.

That is what it is about, and what it has always been about. We started this journey way back in 1982, creating the worlds first modular aluminium trussing system. That invention, and everything that has followed, has been driven by

recognising the needs and demands of a fledgling industry that has since become a global phenomenon – the live events. For us, this means facilitating the build and rebuild of literally thousands of structures every year, and the according

stories of excitement, emotion and joy that are so fundamentally human. So for us that defines it, the need to innovate, to enable and ultimately to continue working towards our end goal: to help you build incredible stuff.

Some history. And the future.

Our founding shareholders all share a connection, back in the early days of the phenomenon that is aluminium trussing. Pioneers and visionaries, together responsible for countless innovations that have framed the landscape of todays marketplace. A casual discussion in Leeds, UK, brought together a few of those bright minds, separated by the passing of time. They started with a simple question – how would we do this

better? Cappuccino's were consumed, and some thoughts were sparked, with the kind of spark that is hard to extinguish. A simple conclusion; what was missing, was passion, and simplicity of purpose that comes with that. Oh, and the right team, a combination of all the experience and lessons learned, with young, dynamic people to drive the future forward. And so the formula for SIXTY82 was discovered...

Bringing together over 100 years of entertainment industry leadership of our shareholders, the company is a British, Dutch and French alliance designed specifically to bring a fresh view in to the market. Headquartered in Drachten, Netherlands, SIXTY82 has every component required to change the way that lightweight structural systems are used. All over again.

Simplicity. By definition, in purchase, in use and in support.

By Definition. In order to do great work, tools need to be a facilitator, not a distraction. They need to work intuitively, be easy to understand yet far reaching in their capability. We call this wide platform modular engineering; behind that we have the strongest technical team in the industry. Their aim is to rationalise products by improving them; reducing inventory, save time and diminish the carbon footprint.

In Purchase. This means that we will have a razor sharp catalogue that is capable of supporting every build:

nothing else. In turn, the experience and knowledge of our dedicated SIXTY82 sales centres will work to ensure rapid availability of every component. We fully understand that non delivery could mean no show.

In Use. With form following function and a restless drive to reduce waste, excess and complexity, our products will be better to work with. From our improved load performance and high production accuracy to the world-first RFID integration. We are producing products that are both easier and more reliable

in use. This leaves room for imagination and creativity and ensures that your end result will be better than ever before.

In Support. We have learnt over the years that our products can only perform with the right level of support. To that end, we have the strongest technical team in the industry, who are here for you if you need any help, from the start of the project to the very end. They are inspired by working every day to ensure that our partners push the boundaries to do incredible things.

Technical Innovation

Technical innovation is at the heart of what we do. This year, we are delighted to launch with a number of world firsts in the trussing and staging industry. Our commitment is to support our technical team deliver innovations and new product launches every season – all designed into a modular roadmap to allow you to efficiently scale your investment – and build incredible things.

RFID Ready

Together with our partners we have combined multiple new technologies into a borderless product management platform. Our RFID system will allow seamless tracking of products, both physically and in terms of technical and origination data. This will give you the confidence that you are using the right products in the right way, every single time.



TÜV Approved

SIXTY82 is employing some leading figures in the field of temporary demountable structures. These people have been involved since the beginning of this century in developing standards in Europe. Accordingly, all of our products are calculated, independently approved and assessed to the latest standards. Furthermore, as the technical pioneer

of many industry leading technologies, SIXTY82 designs its products with integration in mind. This means that technically challenging constructions can be achieved with the same simplicity and peace of mind as the use of individual products.



Clear technical information, available anywhere

With the SIXTY82 app, and our roadmap for RFID integration, we will provide a single support platform which will guide you through the use of our products. This means that you can easily retrieve load, construction and compliance information wherever you are, in a

simple and intuitive way. The platform will continuously be updated with new innovated functionalities such as our SIXTYView and the 3D visualiser, as we develop new technologies driven by our users.

Platform Simplicity

Our promise. Every product will provide solid, reliable service with a simplicity of application. You will get great advice and find a clearer and more focused product range. This means that you will need less different parts in order to achieve more; saving time, space and costs.

Product Personality

General information and address	Article Description	Weight of the article in kilograms
DESIGNED AND MANUFACTURED IN THE EU. USE WITHIN THE LIMITS OF THE STRUCTURAL REPORT AND INTENDED USE WWW.SIXTY82.NL	M29S+L200 Square 200cm Item: 128008 ID: B24102022071	12,34
Manual: can be obtained on www.SIXTY82.nl , in brochure or via QR code	B 22 01 2023 001 location day month year running number (daily reset)	QR code: can be scanned to obtain product code and serial number TUV logo in relation to product approval or EN1090

In this environment, it is vital that you know both the origin and the capabilities of every product that you work with. However, product specifications, traceability and user data have long been a cumbersome for companies and individuals working in this industry. Until now. We believe that simple,

accurate information is a cornerstone of safe building. Accordingly we are proud to launch a suite of tools which centralise data and facilitate easy reference, either physically or digitally, at all times. Our Product Personality system, gives a unique identification to every product and links data about its

specific manufacturing process, and TUV certifications. This is unified by an online database of component information and user manuals, and tied to each individual SIXTYTag. Meaning you have multiple ways to get all of the up to date information of the product and its use, anywhere and any time.

SIXTYTag

The functionality of our Product Personality system is further enhanced with the SIXTYTag – which is standard on every section of trussing that we produce. This unique development of RFID technology combines a special tag with specific









extrusion and mounting design. As a result it is optimised to maximise reading accuracy. It is used within SIXTY82 for the management of stock and designed to facilitate open integration with other systems, enabling the growth of digital asset tracking. We have a roadmap for the development of this unique technology with enhanced functionalities such as EN inspection management and global stock with real-time availability.





Photographer: Ca Greenwood

Content

serie M	TPM29	15
serie M	TPM39	31
serie L	L52	45
serie XL	XL101	51
	Alpha82	54
	Towers	63
	Roof Systems	75
	LED Screen Supports	91
	Stage Modules	97
	Dollies and Extras	123
	Data Center	136
	Custom Projects	138
	Sales Network	140







SIXTY82™

(TPM)

TRUSS SERIES

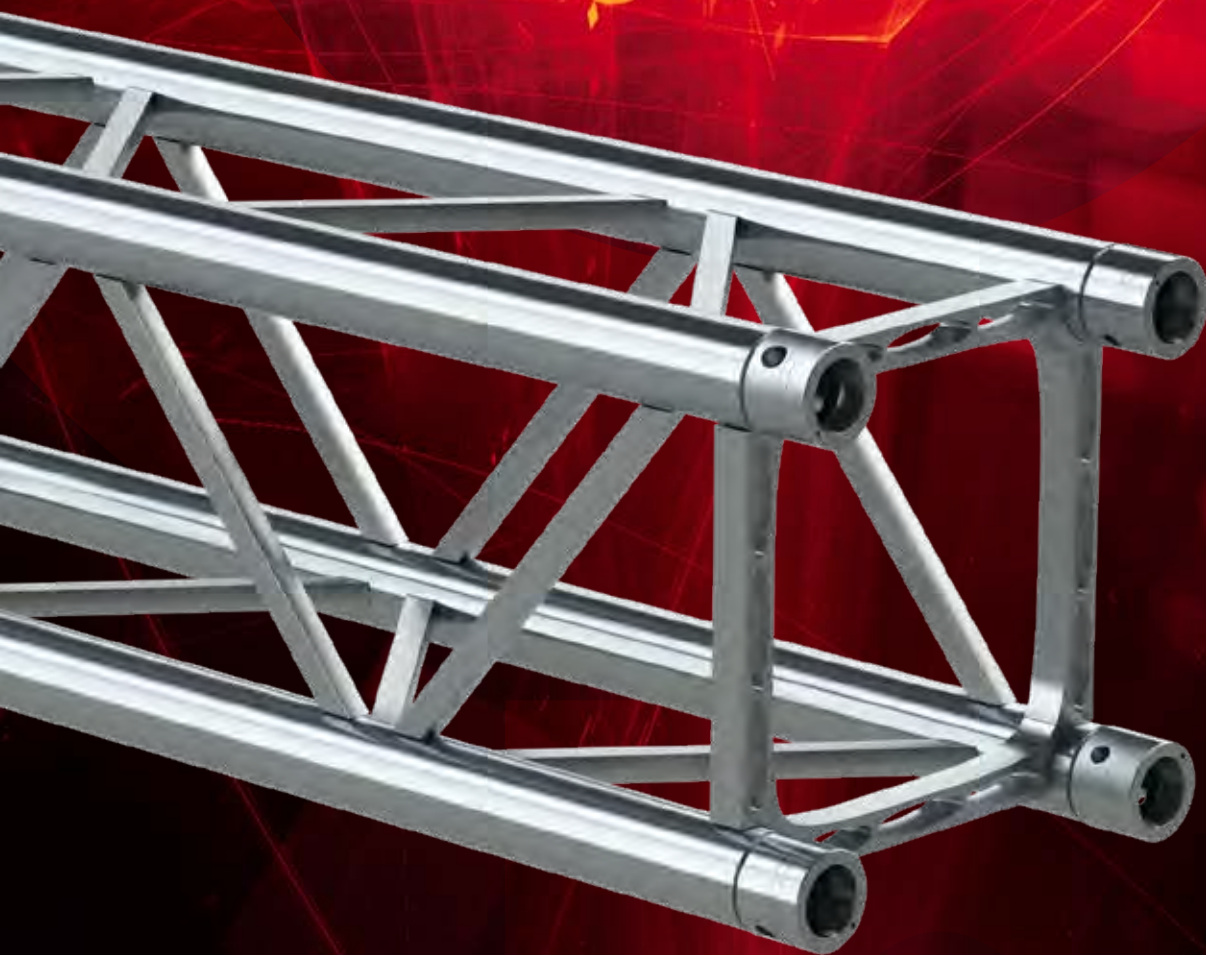

WORLDWIDE PATENT



WE
MADE
IT
FROM
ONE
PIECE

A **REVOLUTIONARY** DESIGN

Introducing the **TPM Truss Series** by **SIXTY82** – the most revolutionary aluminum truss on the market!

Our team at SIXTY82 has spent countless hours researching and developing the perfect aluminum truss, and we are thrilled to finally unveil the TPM Truss Series.

What sets our truss apart from all others is its strength.

We've designed it to be up to 25% stronger, ensuring that your structures will be able to withstand even the most demanding conditions.

And our truss is more than just strong – it's also versatile. It can be used for a wide range of applications, from small events and exhibitions to large-scale concerts and festivals. And with its sleek, modern design, it will add a touch of sophistication to any setting.

Don't just take our word for it – try the TPM Truss Series for yourself and experience the difference.

We're confident that once you do, you'll never go back to using any other truss.

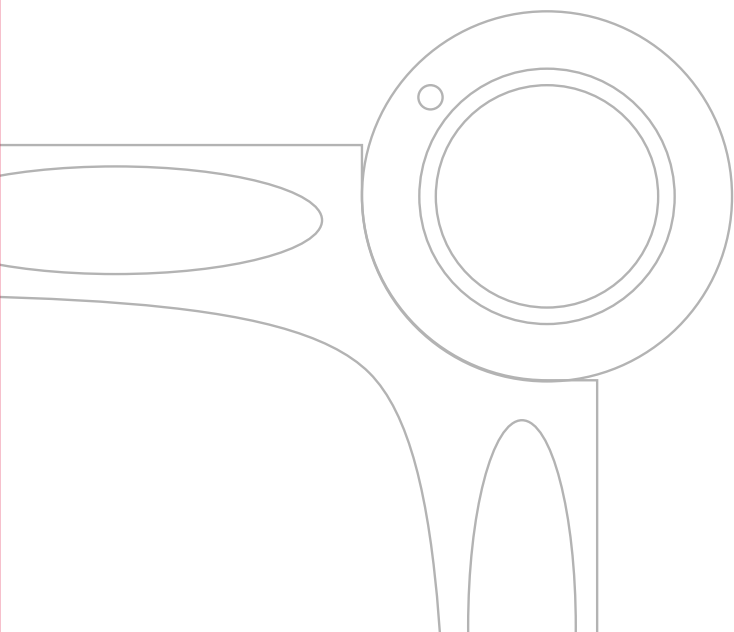

UP TO 25% STRONGER
BOUNCE AND SMASH PROOF
PERFECT FIT

100% INTERCHANGEABLE

EASY TO PLACE LIGHTING FIXTURES
BECAUSE OF END FRAMES



REDESIGNING THE STANDARD

At Sixty82 we have set our self the challenge to re-invent the most used truss type, the M29 Series. The goal was to create an evolution on the standard truss, with beneficial properties over the current M29 Series, while remaining fully interchangeable with the current series.

To achieve these unique properties, we have put countless hours in researching the best solutions. There have been two main innovations to achieve the improved properties.



1

Re-designed diagonal braces

The improved design of the diagonal braces helps to increase the strength and stability of the truss system. By optimizing the shape and dimensions, the diagonal braces are able to provide better support and withstand higher forces. This helps to improve

the overall strength and performance of the truss, making it more effective at supporting heavy loads.

2

Extruded end frame

The use of the extruded end frame contributes to the improved strength and performance of the truss system. By using extruded end frames, the TPM Truss is able to withstand more load without deforming or failing.

In addition to the improved strength, the TPM Truss Series is 100% square and has a perfect fit. This is because the extruded end frames are more precise and uniform in shape, which allows them to more easily and securely attach to other truss components. This can help to improve the stability and strength of the overall truss system, and reduce the risk of failure due to poor connections.

Finally, the removal of the end diagonal allows the inside of the truss to be used for storage and makes it very easy to place uprighters in the truss without the end diagonals interfering.



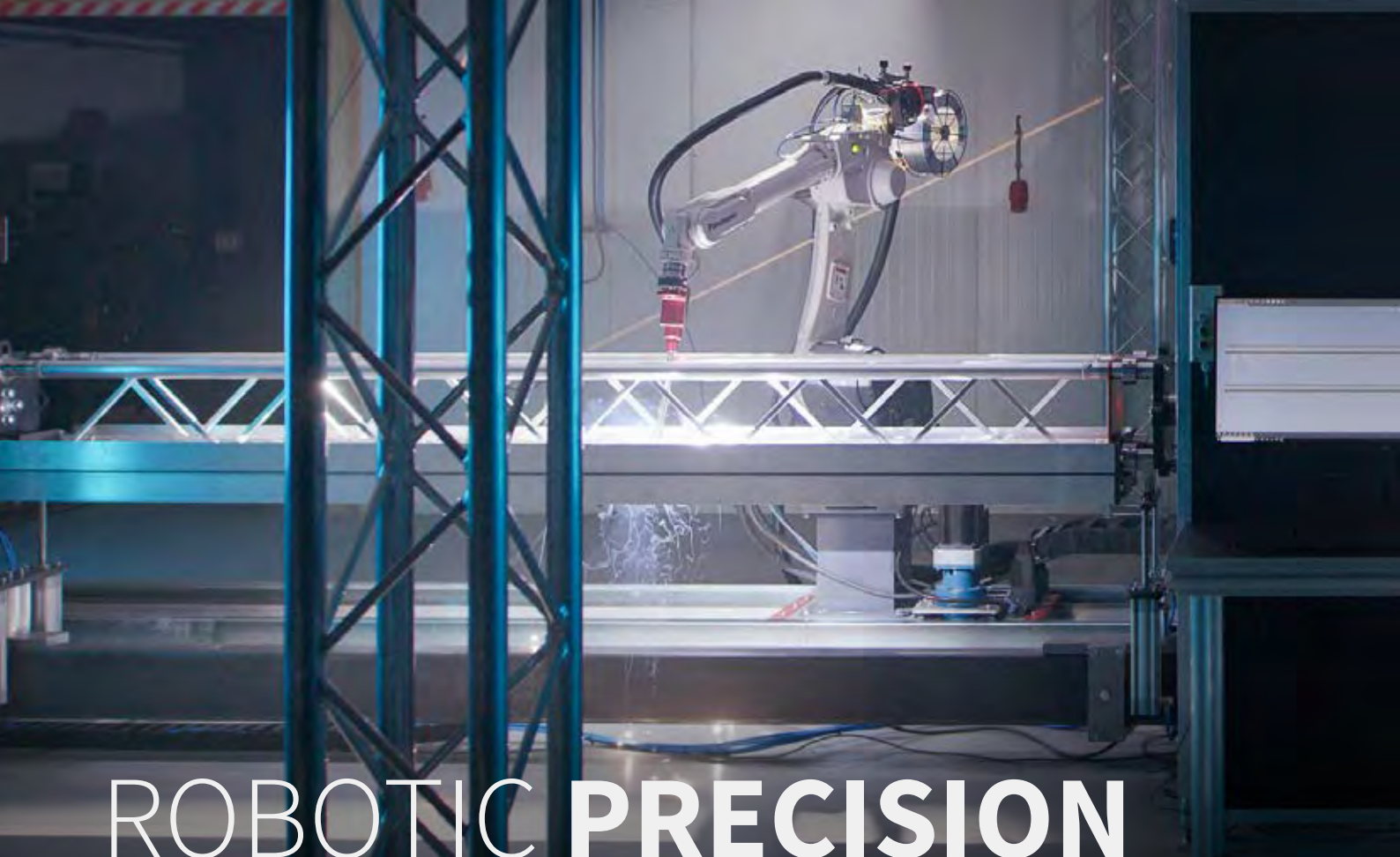

ROBOTIC PRECISION

But It's more than just robotizing

At our company, we have gone above and beyond to optimize the production of our TPM truss. Instead of simply robotizing the existing design, as many others do, we have taken a holistic approach to improving our production process. We have not only implemented advanced robotics technology, but we have also adapted the design of the truss to fit the robotized production process as perfectly as possible.

This unique approach has allowed us to achieve maximum output and produce a top-quality product. Our commitment to innovation and optimization has helped us offer some of the shortest lead times in the market, making us a reliable and efficient choice for our customers. We have a team of highly skilled professionals in-house who have the knowledge and expertise to design and maintain both the truss and the robot installation, ensuring that we are always producing the best possible product.

**MAXIMUM OUTPUT
AND PRODUCE A
TOP-QUALITY
PRODUCT**

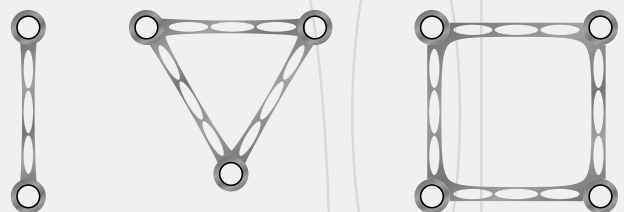

TPM Spigot

An additional key improvement we have made to our TPM truss system is the change in alloy for the truss spigots. By switching to a stronger alloy, we have been able to increase the strength of the truss.

The new spigot is easily distinguishable from the old spigot because of the changed recessed identification line. These new spigots, along with other

optimizations in our production process, have allowed us to offer a product that is up to 25% stronger and more reliable than ever before.



202058 Spigot Model TPM03
202059 Spigot TPM04 M8 Thread

INTERCHANGEABLE

With 100% backwards interchangeability, the TPM truss can be seamlessly integrated into any M29 series setup without any problems. In cases where both truss types are used, customers can simply use the loading tables of the M29 truss for safe and reliable operation.

This backwards interchangeability means that our customers can enjoy all the benefits of the new TPM truss without having to worry about compatibility issues. It's the perfect solution for anyone looking to expand their M29 series and take advantage of the latest innovations in truss technology.

SEAMLESSLY INTEGRATED INTO ANY M29 SERIES

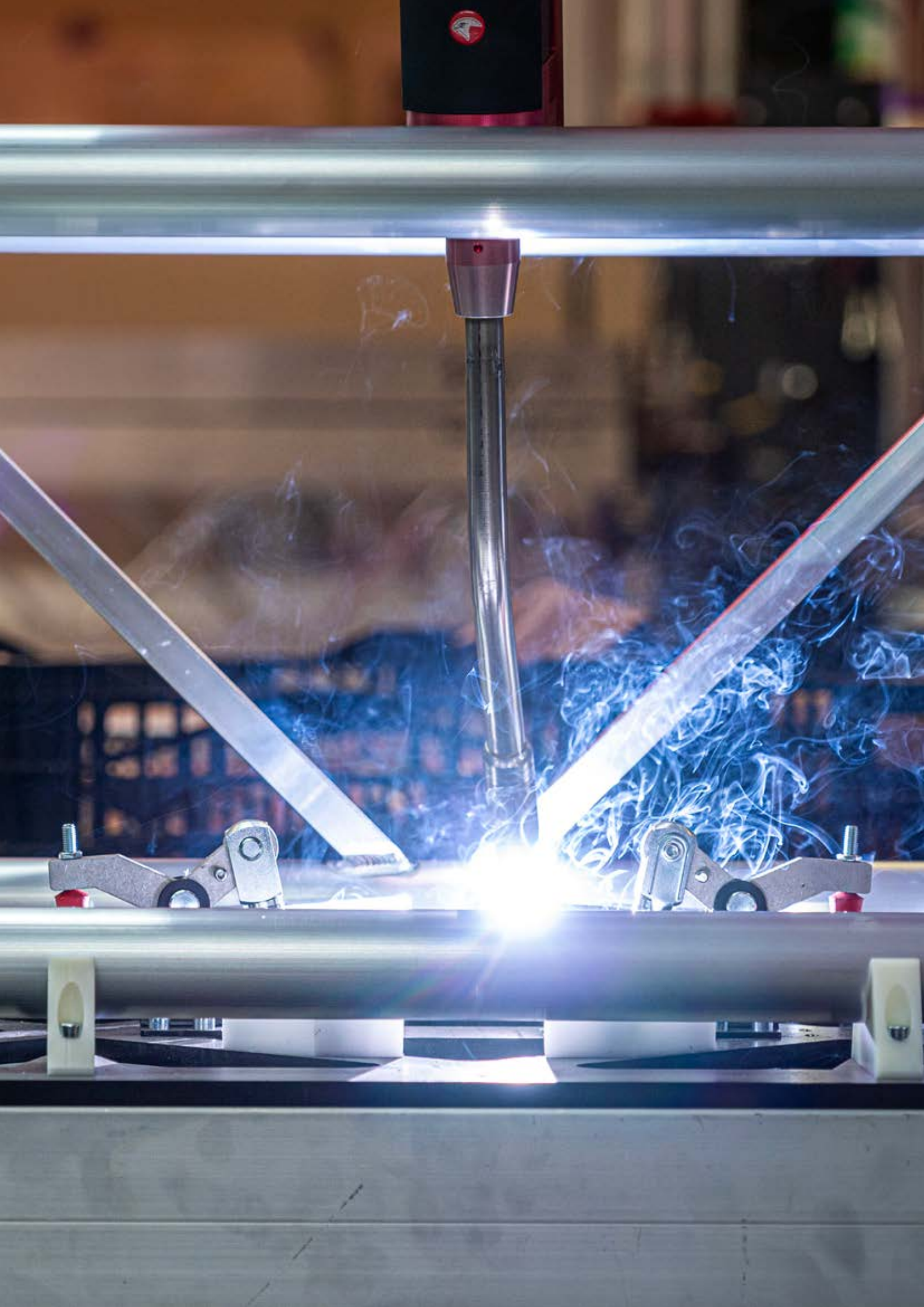

Length

Ladder	16
Triangle	18
Square	19

Corners

Ladder	20
Triangle	22
Square	24

Circle

Square	26
--------	----

Accessories	27
--------------------	----

Middle beam	28
--------------------	----

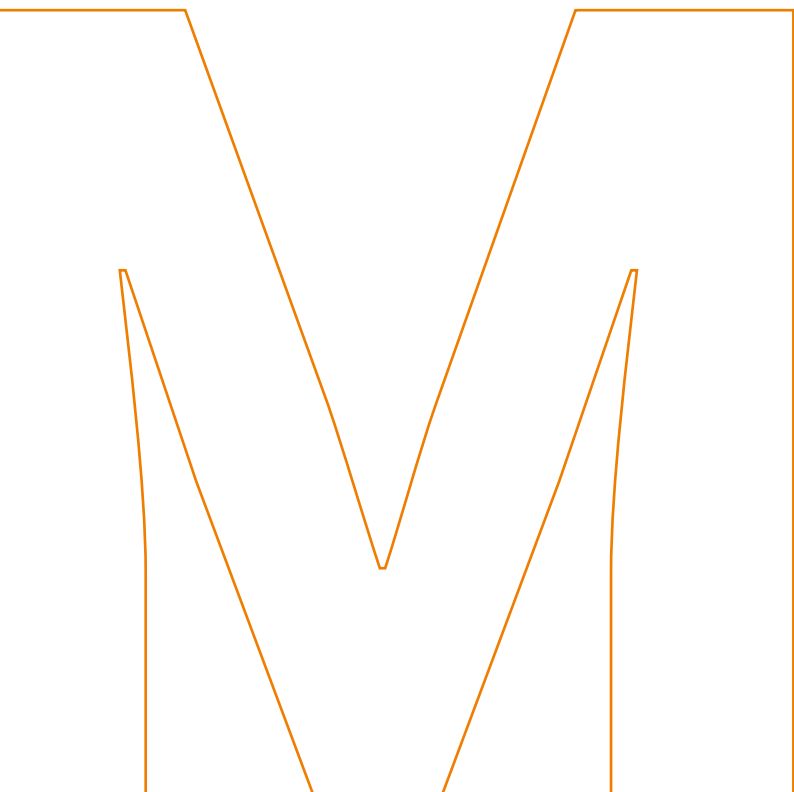

TPM29L Length Ladder

● 48.3 x 3 mm

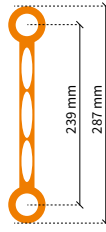
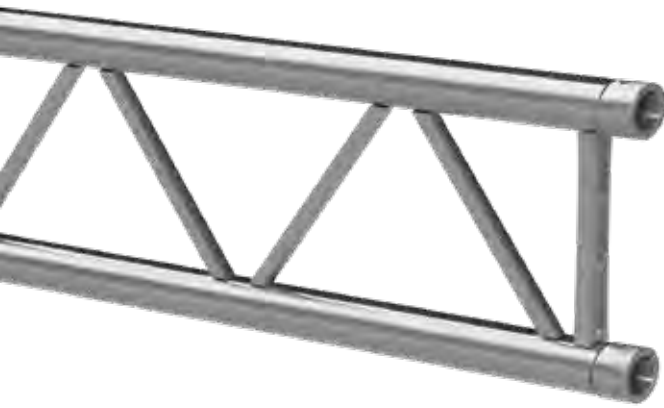

2.8 kg/m

M

ALU/BLACK

(RFID)
READY

P.136

TPM29L

Code	Length
121501	21 cm
121502	25 cm
121503	50 cm
121514	60 cm
121504	71 cm
121515	75 cm
121505	100 cm
121506	150 cm
121507	200 cm
121508	250 cm
121509	300 cm
121511	400 cm
121513	500 cm

Load table single span, supported sideways every 1 meter at top chord TPM29L

Span m	CPL kg	Deflection mm	2 x load kg	Deflection mm	3 x load kg	Deflection mm	4 x load kg	Deflection mm	UDL kg/m	Deflection mm
2.0	976.5	4	488.3	5	325.5	4	244.1	5	488.3	5
3.0	779.0	8	486.9	10	324.6	10	243.5	10	324.6	10
4.0	625.0	15	422.3	19	323.7	17	242.8	19	242.8	18
5.0	520.9	23	357.8	29	286.7	27	223.8	29	193.7	28
6.0	445.7	33	309.8	42	241.9	39	190.6	42	161.0	41
8.0	343.8	58	243.0	74	183.1	69	146.2	74	96.0	73
10.0	277.6	91	198.5	116	146.2	108	117.6	116	60.9	114
11.0	252.3	110	181.3	140	132.3	131	106.8	140	50.0	137
12.0	230.7	131	166.5	167	120.5	155	97.5	167	41.7	164

Load table single span, supported sideways every 2 meter at top chord TPM29L

Span m	CPL kg	Deflection mm	2 x load kg	Deflection mm	3 x load kg	Deflection mm	4 x load kg	Deflection mm	UDL kg/m	Deflection mm
2.0	389.0	1	291.8	1	194.5	1	162.1	1	389.0	1
3.0	257.1	2	192.8	3	128.5	2	107.1	3	171.4	2
4.0	190.5	4	142.8	5	95.2	4	79.4	5	95.2	4
5.0	149.9	6	112.4	7	75.0	7	62.5	7	60.0	7
6.0	122.5	8	91.9	10	61.2	9	51.0	10	40.8	10
8.0	87.1	14	65.3	18	43.6	17	36.3	18	21.8	18
10.0	64.8	22	48.6	28	32.4	26	27.0	28	13.0	28
11.0	56.4	27	42.3	34	28.2	32	23.5	34	10.2	33
12.0	49.1	32	36.8	41	24.5	38	20.5	41	8.2	40

Load table free span TPM29L

Span m	CPL kg	Deflection mm	2 x load kg	Deflection mm	3 x load kg	Deflection mm	4 x load kg	Deflection mm	UDL kg/m	Deflection mm
1.0	979.2	1	489.6	1	326.4	1	244.8	1	979.2	1
2.0	389.0	1	291.8	1	194.5	1	162.1	1	389.0	1
3.0	234.0	2	176.0	2	117.0	2	98.0	2	156.0	2
4.0	146.0	3	110.0	3	73.0	3	61.0	3	73.0	3
5.0	90.0	3	68.0	4	45.0	4	38.0	4	36.0	4





Find complete loading tables on SIXTY82.nl

All loading data is based on calculations per EN-1999-1-1 and the following assumptions:

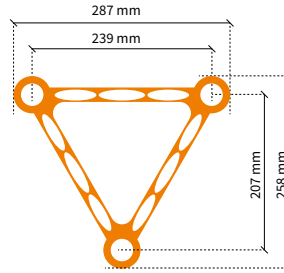
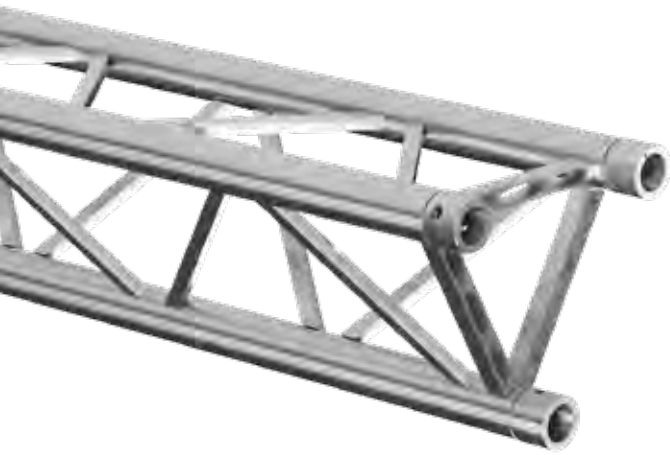
- Static loads only.
- Spans supported or suspended at both ends.
- Triangle trusses solely used apex-up, apex-down.
- 2 chords truss to be placed upright, supported from top chord and loaded from bottom chord.
- Truss spans can be constructed of elements of different length.
- Interaction between bending moment and shear force considered.
- Self-weight of truss is already considered.
- Assembled truss systems need an individual structural calculation. Please contact SIXTY82 or a structural engineer.
- Read the manual before use.
- Higher loading can be allowed depending on the truss configuration.





-  4.7 kg/m
-  M
-  ALU/BLACK
-  (RFID) READY
-  P.136

TPM29T

Code	Length
125501	21 cm
125502	25 cm
125503	29 cm
125504	50 cm
125505	71 cm
125506	100 cm
125507	150 cm
125508	200 cm
125509	250 cm
125510	300 cm
125512	400 cm
125514	500 cm

Load table TPM29T

Span m	CPL kg	Deflection mm	2 x load kg	Deflection mm	3 x load kg	Deflection mm	4 x load kg	Deflection mm	UDL kg/m	Deflection mm
2.0	1620.2	3	1062.6	4	708.4	4	531.3	4	1062.6	4
4.0	802.0	12	601.5	16	401.0	15	334.2	16	401.0	15
6.0	525.7	28	394.3	36	262.8	33	219.0	36	175.2	35
8.0	384.8	49	288.6	63	192.4	59	160.3	63	96.2	62
10.0	298.1	77	223.6	99	149.1	92	124.2	99	59.6	97
12.0	238.5	111	178.9	142	119.3	132	99.4	142	39.8	139
14.0	194.4	151	145.8	193	97.2	180	81.0	193	27.8	189
16.0	160.0	198	120.0	253	80.0	235	66.7	253	20.0	247
20.0	108.6	309	81.4	395	54.3	367	45.2	395	10.9	386

Cantilever load

Span m	1 x Load kg	Deflection mm	UDL kg/m	Deflection mm
0.5	1066.7	0.1	2130.7	0.2
1.0	810.1	1.6	1062.6	01.5
1.5	537.8	5.2	706.6	05.1
2.0	401.0	12.4	401.0	09.3
2.5	318.4	24.1	254.7	14.5
3.0	262.8	41.5	175.2	20.9
3.5	222.8	65.4	127.3	28.5
4.0	192.4	96.7	96.2	37.3

Multiple supported span

Span m	CPL kg	Deflection mm	2 x load kg	Deflection mm	UDL kg/m	Deflection mm
2.0	1543.7	1	791.1	1	849.0	0.8
4.0	1072.2	7	602.1	7	401.0	6.3
6.0	702.8	16	394.6	15	175.2	14
8.0	514.4	28	288.9	26	96.2	24.4
10.0	398.6	42	223.8	39	59.6	36.9
12.0	318.9	59	179.1	54	39.8	51
14.0	259.9	76	146.0	69	27.8	66
16.0	213.9	93	120.1	85	20.0	81
20.0	145.1	123	81.5	113	10.9	124.7

Find complete loading tables on SIXTY82.nl

All loading data is based on calculations per EN-1999-1-1 and the following assumptions:





- Static loads only.
- Spans supported or suspended at both ends.
- Triangle trusses solely used apex-up, apex-down.
- 2 chords truss to be placed upright, supported from top chord and loaded from bottom chord.
- Truss spans can be constructed of elements of different length.

- Interaction between bending moment and shear force considered.
- Self-weight of truss is already considered.
- Assembled truss systems need an individual structural calculation. Please contact SIXTY82 or a structural engineer.
- Read the manual before use.
- Higher loading can be allowed depending on the truss configuration.

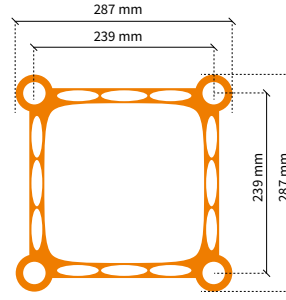
48.3 x 3 mm

TPM29S Length Square



-  6.4 kg/m
-  M
-  ALU/BLACK
-  ((RFID))
READY
-  P.136

TPM29S

Code	Length
128501	21 cm
128502	25 cm
128503	29 cm
128504	50 cm
128505	71 cm
128515	75 cm
128506	100 cm
128507	150 cm
128508	200 cm
128509	250 cm
128510	300 cm
128512	400 cm

Load table TPM29S

Span	CPL	Deflection	2 x load	Deflection	3 x load	Deflection	4 x load	Deflection	UDL	Deflection
m	kg	mm	kg	mm	kg	mm	kg	mm	kg/m	mm
2.0	2455.0	3	1227.5	4	818.3	4	613.7	4	1227.5	4
4.0	1399.4	13	972.3	17	779.7	16	610.9	17	610.9	17
6.0	985.9	30	695.2	38	526.7	35	419.7	38	377.0	37
8.0	755.7	53	541.1	68	397.4	63	320.2	68	209.5	66
10.0	607.9	83	440.0	106	316.5	98	256.8	106	132.0	103
12.0	504.2	119	368.0	152	260.6	141	212.7	152	89.9	149
14.0	426.7	162	313.8	207	219.4	192	179.8	207	64.5	202
16.0	366.2	212	271.1	270	187.6	251	154.3	270	48.1	264
20.0	276.5	330	207.5	422	140.8	392	116.6	422	28.7	413

Cantilever load

Span	1 x Load	Deflection	UDL	Deflection
m	kg	mm	kg/m	mm
0.5	1231.8	1	2460.8	0.01
1.0	1230.4	12	1227.5	0.09
1.5	880.0	43	816.4	0.30
2.0	698.0	10.8	610.9	0.71
2.5	577.2	21.9	410.9	1.17
3.0	491.0	38.7	290.3	1.73
3.5	426.3	62.4	219.3	2.43
4.0	375.8	94	171.2	3.27

Multiple supported span

Span	CPL	Deflection	2 x Load	Deflection	UDL	Deflection
m	kg	mm	kg	mm	kg/m	mm
2.0	1783.4	1	914.4	0.1	980.8	0.5
4.0	1703.4	6	903.6	0.5	487.5	3.9
6.0	1184.9	14	653.0	1.2	283.0	11.4
8.0	927.6	25	513.3	2.3	163.7	20.9
10.0	756.1	41	419.5	3.7	107.9	33.6
12.0	632.6	59	351.7	5.3	75.8	49.0
14.0	538.7	79	299.9	7.2	55.6	66.7
16.0	464.4	102	258.9	9.3	42.2	86.2
20.0	352.7	151	197.0	13.8	25.8	144.7

Find complete loading tables on SIXTY82.nl

All loading data is based on calculations per EN 17115:2018 and the following assumptions:

- Static loads only.
- Spans supported or suspended at both ends.
- Triangle trusses solely used apex-up, apex-down.
- 2 chords truss to be placed upright or supported from top chord and loaded from bottom chord.
- Truss spans can be assembled from elements of different length.
- Loading data is only applicable when trusses are solely assembled with TPM03/04 (42CrMo4) spigots.

- Interaction of bending moment and shear force considered.
- Self-weight of truss is already considered.
- Assembled truss structures need an individual structural calculation, please contact SIXTY82 or a structural engineer.
- Read the manual before use.
- Higher loading can be allowed depending on the truss configuration.

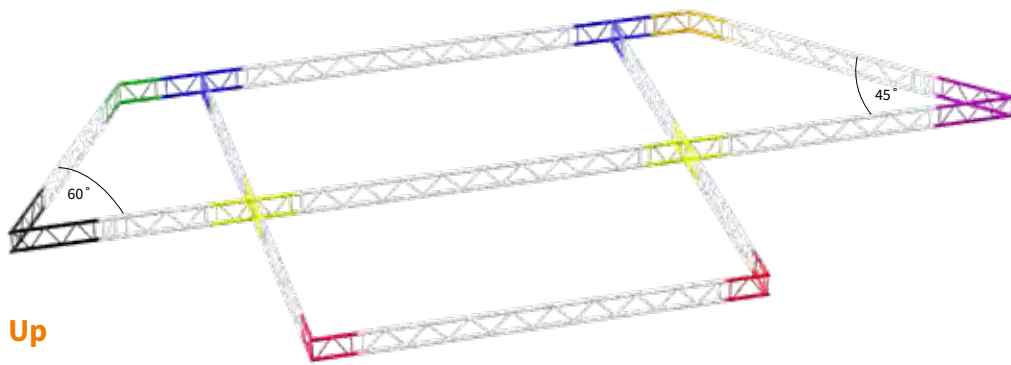

Up

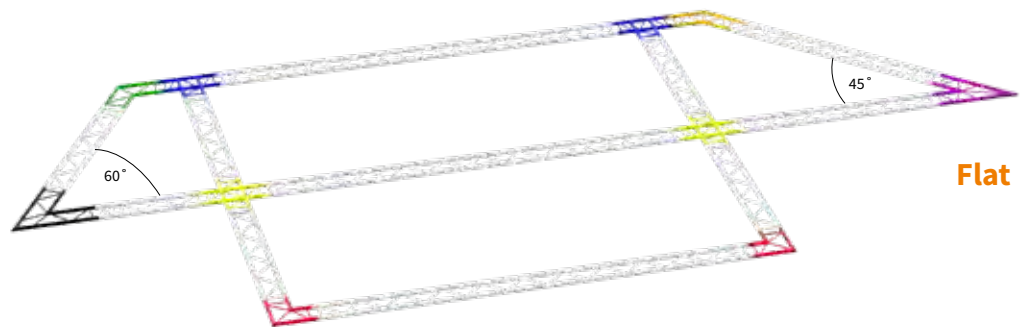

Flat

2way
up

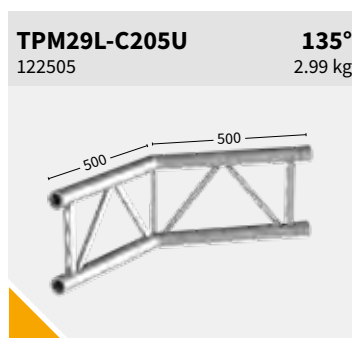
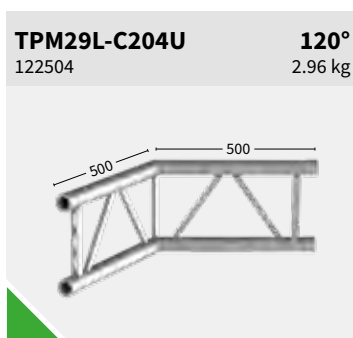
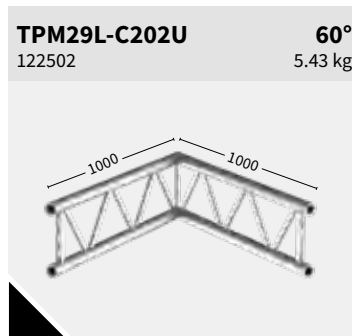
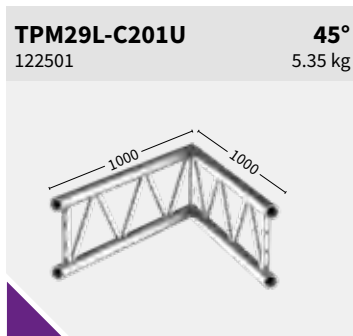

2way
flat



3way



4way



Box

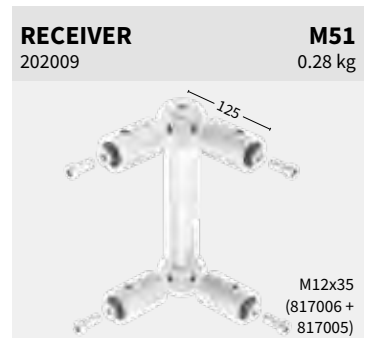
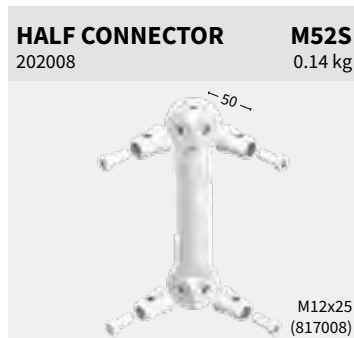

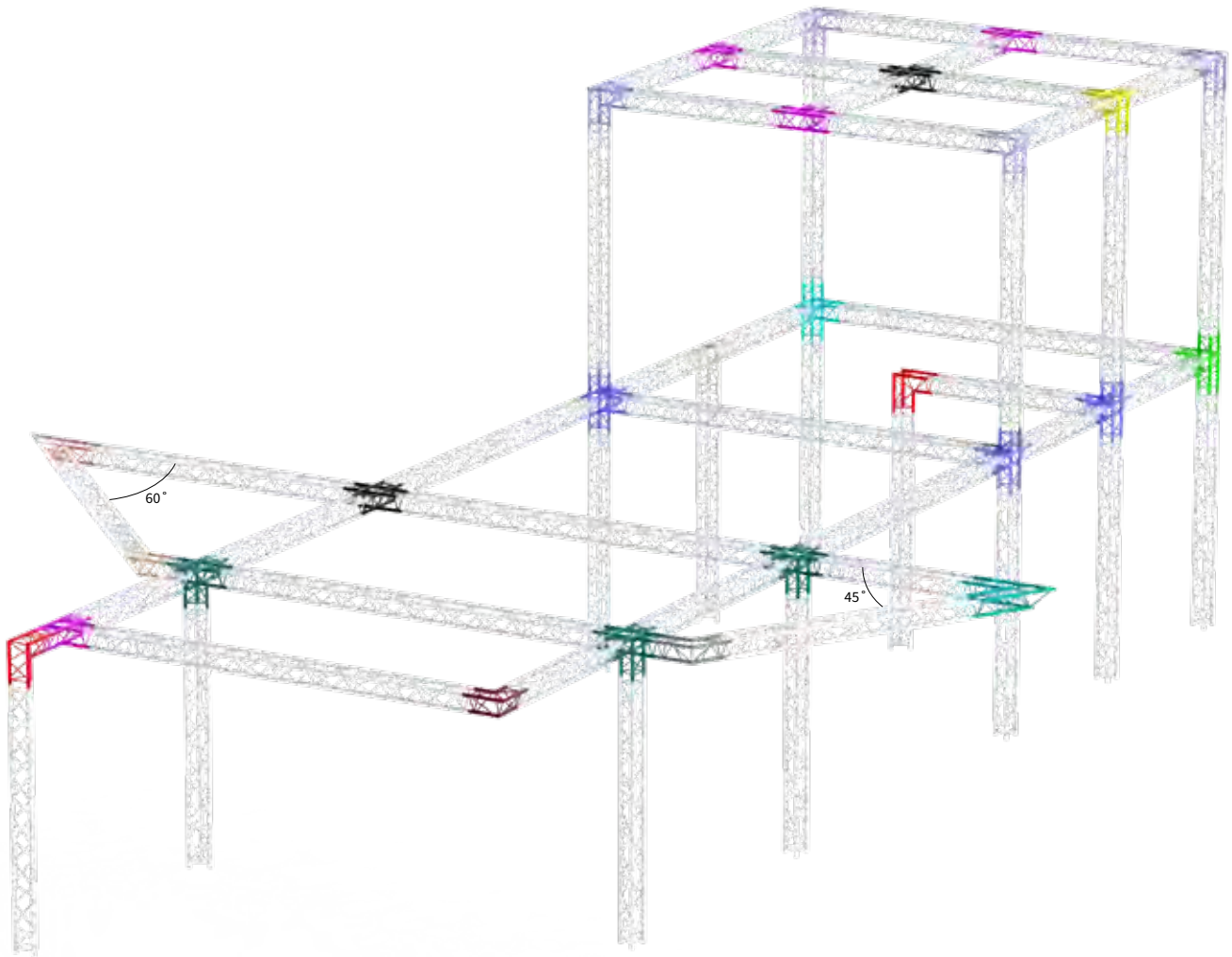

2way

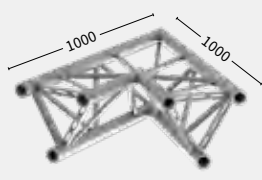
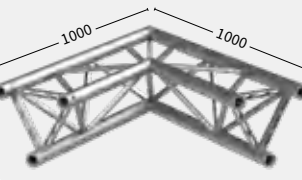
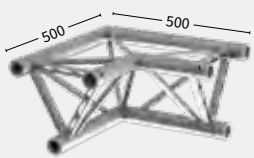
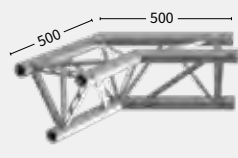
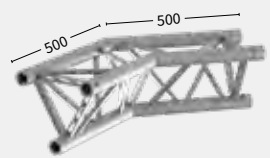
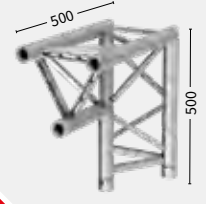
<p>TPM29T-C201 126501</p> <p>45° 6.43 kg</p> 	<p>TPM29T-C202 126502</p> <p>60° 7.11 kg</p> 	<p>TPM29T-C203 126503</p> <p>90° 3.79 kg</p> 
<p>TPM29T-C204 126504</p> <p>120° 4.32 kg</p> 	<p>TPM29T-C205 126505</p> <p>135° 4.63 kg</p> 	<p>TPM29T-C207 126506</p> <p>90° 4.23 kg</p> 

3way

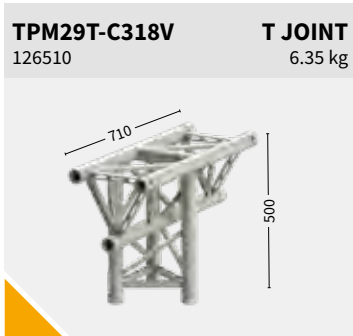
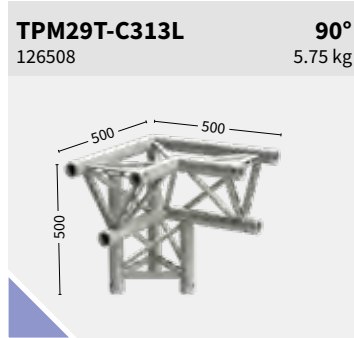
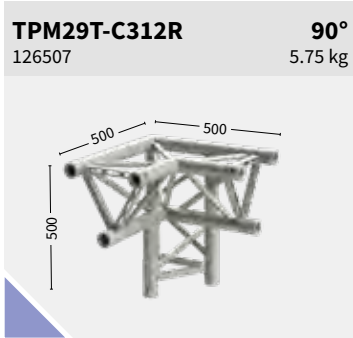

4way

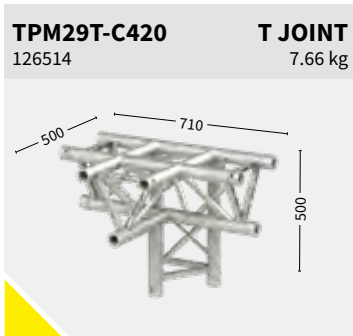
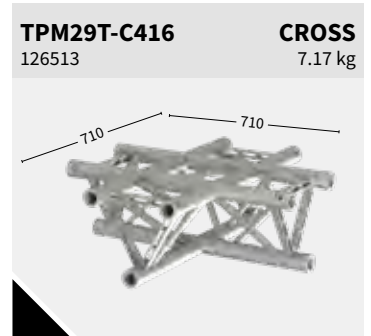
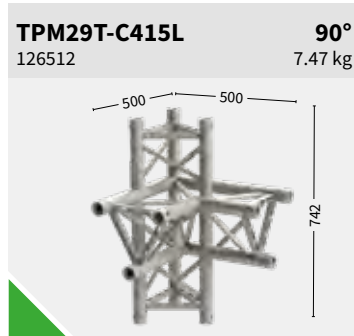
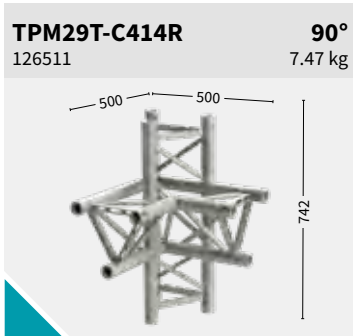

5way

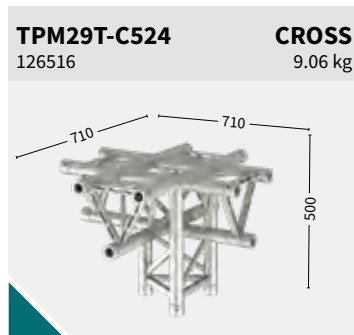
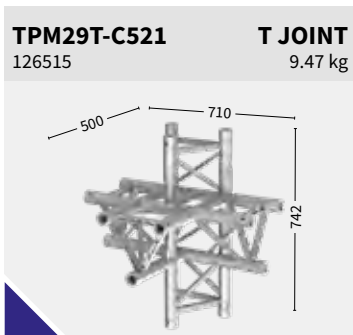

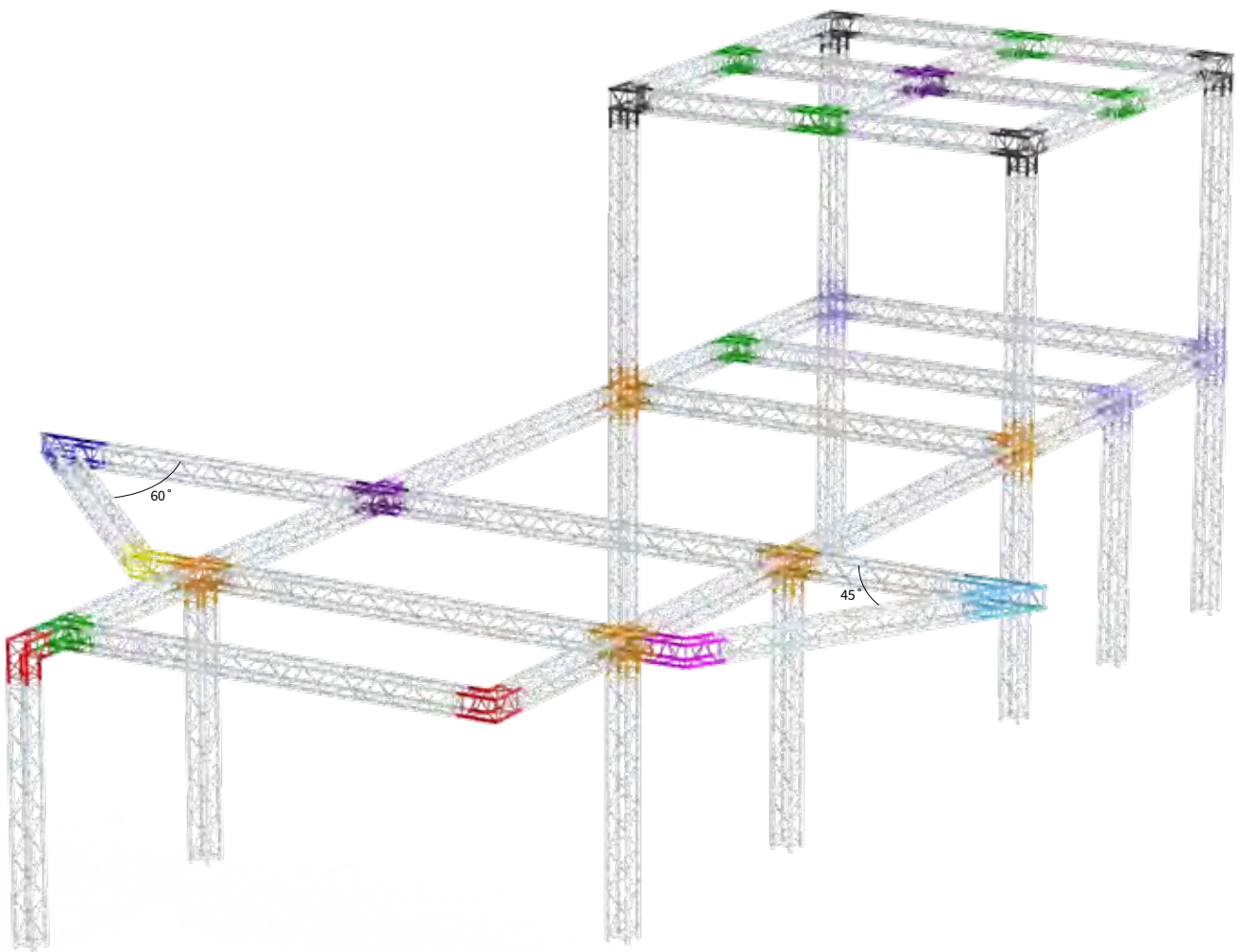

2way

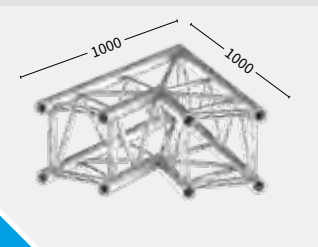
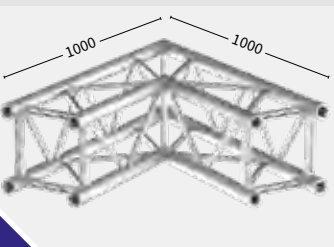
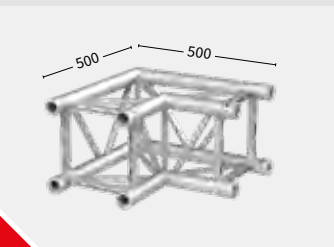
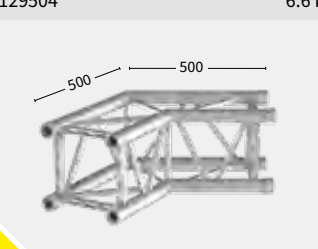
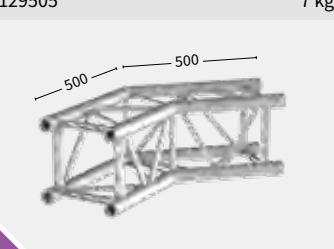
<p>TPM29S-C201 129501</p> <p>45° 9.7 kg</p> 	<p>TPM29S-C202 129502</p> <p>60° 10.6 kg</p> 	<p>TPM29S-C203 129503</p> <p>90° 5.9 kg</p> 
<p>TPM29S-C204 129504</p> <p>120° 6.6 kg</p> 	<p>TPM29S-C205 129505</p> <p>135° 7 kg</p> 	

3way

TPM29S-C312 **90°**
129506 8 kg

TPM29S-C317 **T JOINT**
129507 8.9 kg

TPM29S-C350 **T JOINT**
129511 7 kg

4way

TPM29S-C416 **CROSS**
129508 11 kg

TPM29S-C420 **T JOINT**
129509 11 kg

5way

TPM29S-C524 **CROSS**
129510 13.1 kg

BOX

BOX CORNER **M29S**
199002 8.5 kg

With locator holes

HALF CONNECTOR **M52S**
202008 0.14 kg

M12x25 (817008)

RECEIVER **M51**
202009 0.28 kg

M12x35 (817006 + 817005)

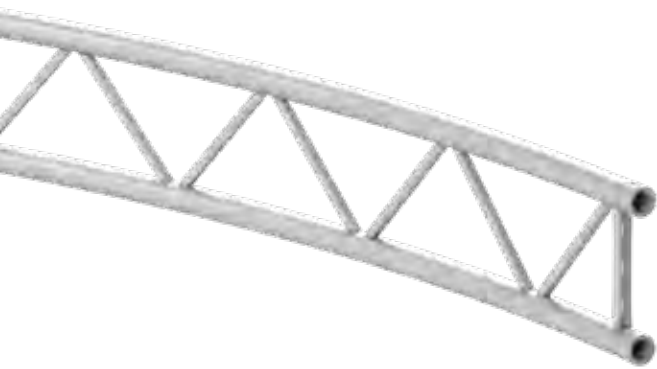

-  3 kg/m
-  M
-  ALU/BLACK
-  ((RFID))
READY
-  P.136

TPM29L Circle part - up

Code	∅ Diameter	Angle	Parts/Circle
124501	2 m	90	4
124502	3 m	90	4
124503	4 m	90	4
124504	5 m	90	4



-  3 kg/m
-  M
-  ALU/BLACK
-  ((RFID))
READY
-  P.136

TPM29L Circle part - flat

Code	∅ Diameter	Angle	Parts/Circle
124505	2 m	90	4
124506	3 m	90	4
124507	4 m	90	4
124508	5 m	90	4

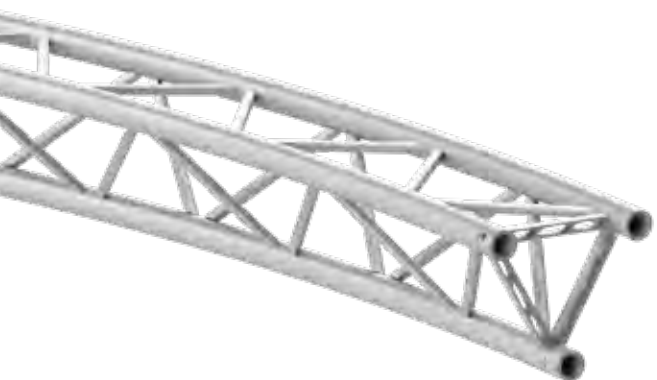

-  5 kg/m
-  M
-  ALU/BLACK
-  ((RFID))
READY
-  P.136

TPM29T Circle part

Code	∅ Diameter	Angle	Parts/Circle
127501	2 m	90	4
127502	3 m	90	4
127503	4 m	90	4
127504	5 m	90	4
127505	6 m	45	8
127506	8 m	45	8
127507	10 m	30	12
127508	10 m	45	8



-  6.4 kg/m
-  M
-  ALU/BLACK
-  ((RFID))
READY

TPM29S Circle part

Code	∅ Diameter	Angle	Parts/Circle
130501	2 m	90	4
130502	3 m	90	4
130503	4 m	90	4
130504	5 m	90	4
130505	6 m	45	8
130506	8 m	45	8
130507	10 m	30	12
130508	10 m	45	8

• Subject to tolerance, because product is 100% handmade.

BASE PLATE M29T
211003 1.01 kg

M49 + M12x20
(202007 + 817003)

BASE PLATE M29S
211004 1.65 kg

M49 + M12x20
(202007 + 817003)

LIFTING BRACKET M29S
212001 2.55 kg

WLL 1000 kg

HANG-ON82 M29 TO M29S-T
251003 10.2 kg

HANG-ON82 M29 TO M29L
251004 7.06 kg

BOOK CORNER M29S-T
198001 11.3 kg

WALL ADAPTER M29S-T
212006 4.35 kg

BOOK-FIX M29S-T
198004 4.43 kg

Also needed: 207002 Clamp
M36 tube 50mm swivel WLL 750kg

STEEL BASE M29S
211019

TRUSS HINGE TPM29S

Code	Finish
211020	Black
211021	Zinc

LIFTINGPLATE M29S-T/M39R

Code	Finish
212010	Black
212011	Zinc

BASE PLATE STEEL M29/39S-T

Code	Finish	Weight
211009	Black	35 kg
211010	Zinc	

M49 + M12x25
(202007 + 817049)

BASE PLATE STEEL M29/M39S-T

Code	Finish	Weight
211011	Black	41 kg
211012	Zinc	

M49 + M12x25
(202007 + 817049)



TPM29SMB Middle Beam

-  6.4 kg/m
-  M
-  ALU/BLACK
-  ((RFID))
READY

Code	Length
120506	100 cm
120507	150 cm
120508	200 cm
120509	250 cm
120510	300 cm

BOX corner invention evolved

Locator pin design and special male connector will allow much easier user configuration of box corners.

Higher shear force capacity due to lower eccentricity when using male connectors.

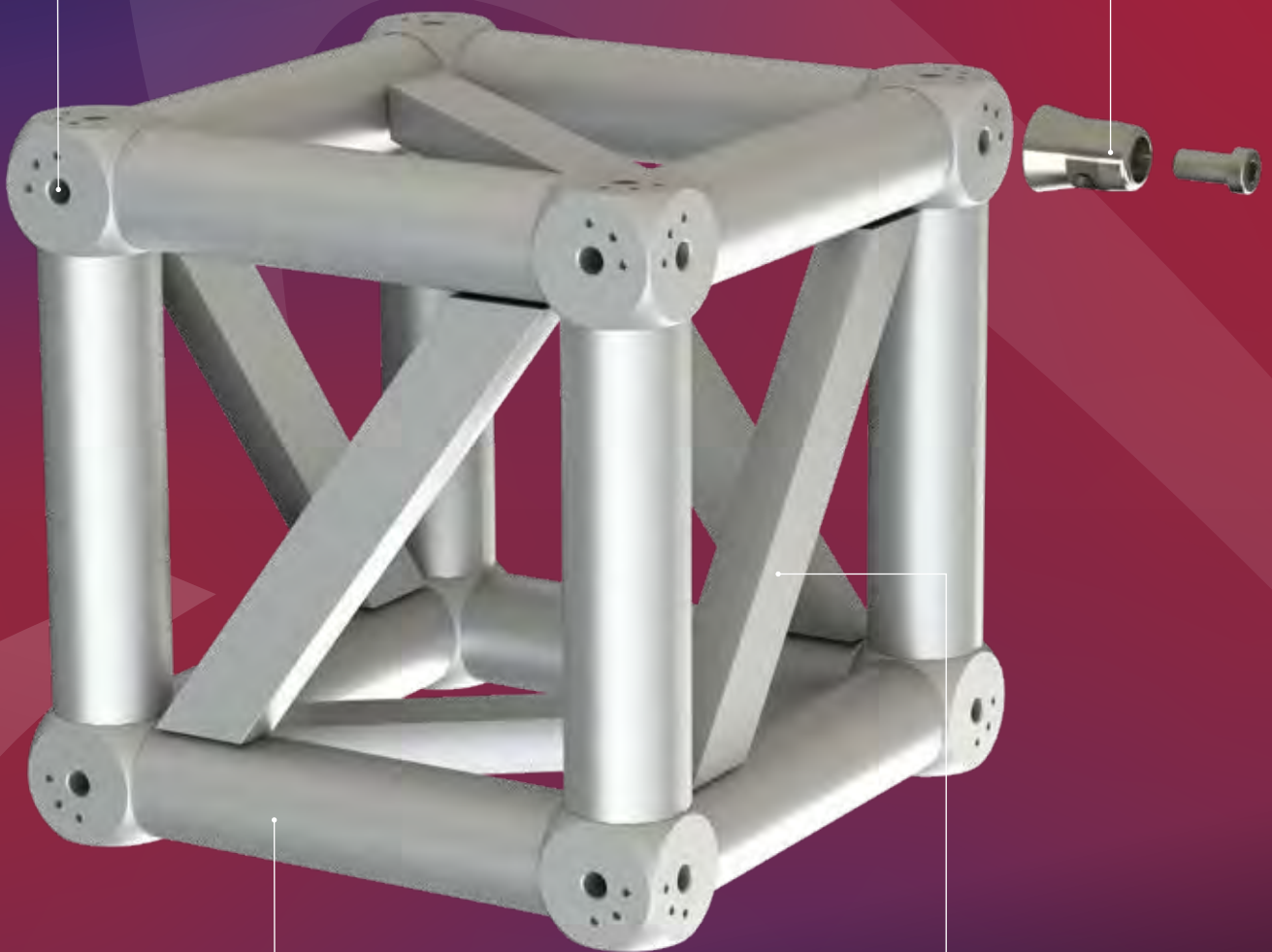

Less components giving increased user simplicity and better value.

High allowable bending moment due to bigger diagonal.



Length

Square	32
--------	----

Corners

Square	34
--------	----

Circle

Square	36
--------	----

Middle beam	36
--------------------	----

TPM39RP Length Square	37
------------------------------	----

Accessories	38
--------------------	----

Hang-on82	40
------------------	----

Wall adapter82	42
-----------------------	----

Accessories M Series	43
-----------------------------	----



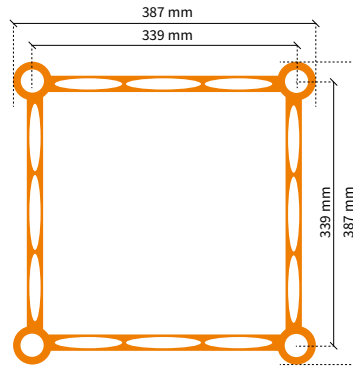
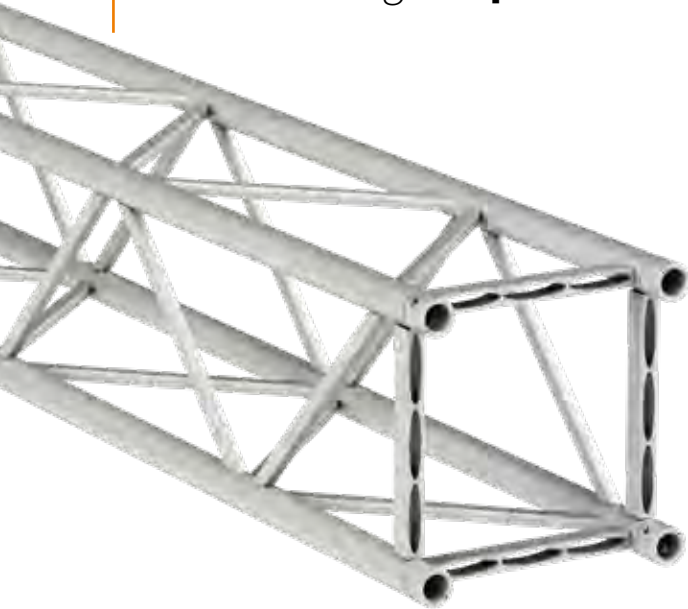

TPM39S

Code	Length
138501	21 cm
138502	25 cm
138504	50 cm
138505	81 cm
138506	100 cm
138508	200 cm
138510	300 cm
138512	400 cm

6.9 kg/m

(RFID)
READY

M

P.136

ALU/BLACK

Load table TPM39S

Span m	CPL kg	Deflection mm	2 x load kg	Deflection mm	3 x load kg	Deflection mm	4 x load kg	Deflection mm	UDL kg/m	Deflection mm
2	3054.3	2	1527.2	3	1018.1	3	763.6	3	1527.2	3
4	1840.9	9	1275.3	12	1014.0	11	760.5	12	760.5	12
6	1329.0	21	916.4	27	728.4	25	570.3	27	504.9	26
8	1035.1	38	727.1	48	555.5	45	441.3	48	299.2	47
10	843.3	59	600.0	75	446.5	70	358.0	75	189.2	73
12	707.5	85	508.3	108	371.1	100	299.6	108	129.5	106
14	605.7	115	438.7	147	315.5	137	256.0	147	93.5	144
16	526.1	150	383.7	192	272.5	179	222.1	192	70.1	188
18	461.8	190	339.0	243	238.1	226	194.8	243	54.1	238
20	408.4	235	301.6	300	209.8	279	172.2	300	42.6	294

Cantilever load

Span m	1 x Load kg	Deflection mm	UDL kg/m	Deflection mm
0.5	1531.8	0	3060.6	0.1
1.0	1530.3	0.7	1527.2	0.6
1.5	1149.3	2.8	1016.0	1.9
2.0	918.3	7.1	760.5	4.4
2.5	770.0	14.6	535.7	7.6
3.0	662.0	26.1	380.2	11.3
3.5	579.7	42.4	287.3	15.9
4.0	514.9	64.4	226.6	21.6

Multiple supported span

Span m	CPL kg	Deflection mm	2 x Load kg	Deflection mm	UDL kg/m	Deflection mm
2	2219.1	0	1139.5	0	1220.5	0.3
4	2183.8	4	1128.7	3	607.1	2.4
6	1542.7	9	858.2	8	367.7	7.5
8	1234.4	17	679.4	15	213.6	13.7
10	1023.3	28	565.0	25	143.5	22.4
12	868.9	40	480.8	36	102.5	33.2
14	750.3	55	415.9	50	76.4	45.9
16	655.9	72	364.1	65	58.8	60.3
18	578.4	91	321.4	82	46.3	76.1
20	513.4	110	285.6	100	37.2	103.6

Find complete loading tables on SIXTY82.nl

All loading data is based on calculations per EN-1999-1-1 and the following assumptions:

- Static loads only.
- Spans supported or suspended at both ends.
- Triangle trusses solely used apex-up, apex-down.
- 2 chords truss to be placed upright, supported from top chord and loaded from bottom chord.
- Truss spans can be constructed of elements of different length.

- Interaction between bending moment and shear force considered.
- Self-weight of truss is already considered.
- Assembled truss systems need an individual structural calculation. Please contact SIXTY82 or a structural engineer.
- Read the manual before use.
- Higher loading can be allowed depending on the truss configuration.

Truss terminology... **what is what?**

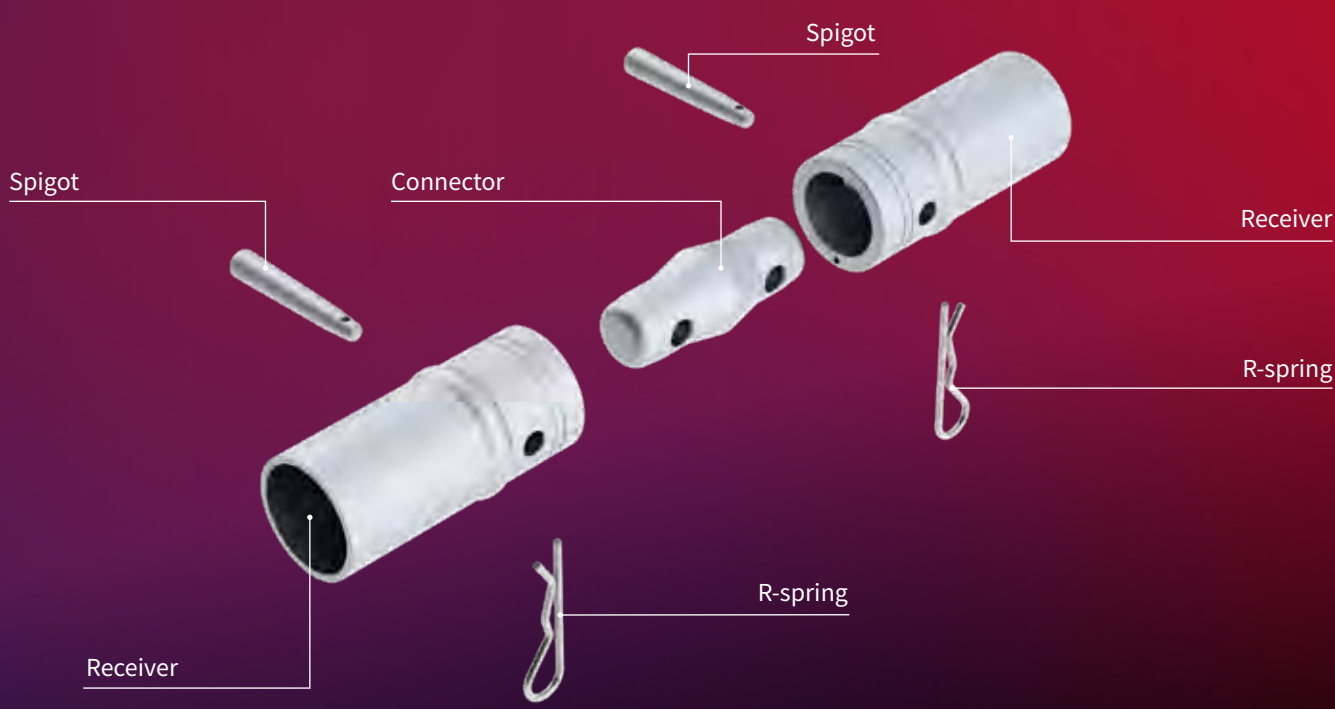
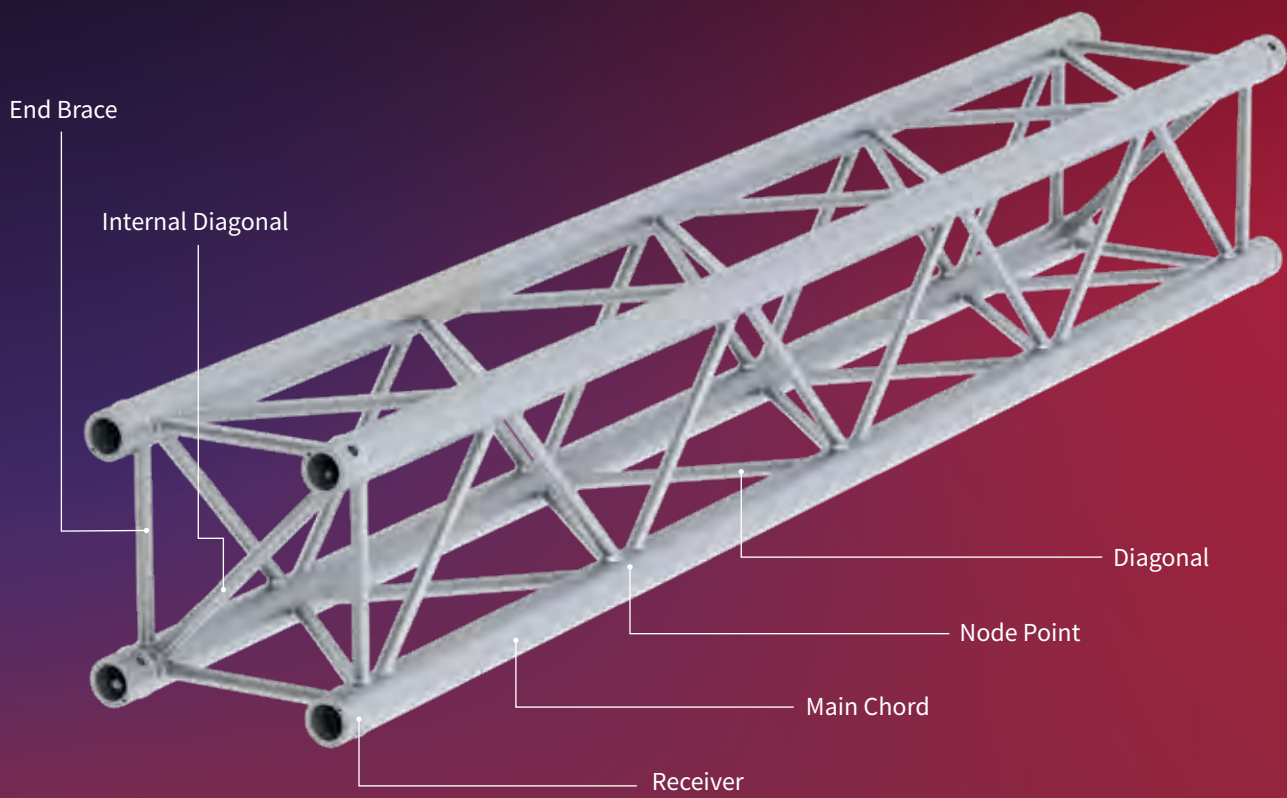

For further information, please refer to the SIXTY82 original user manual.

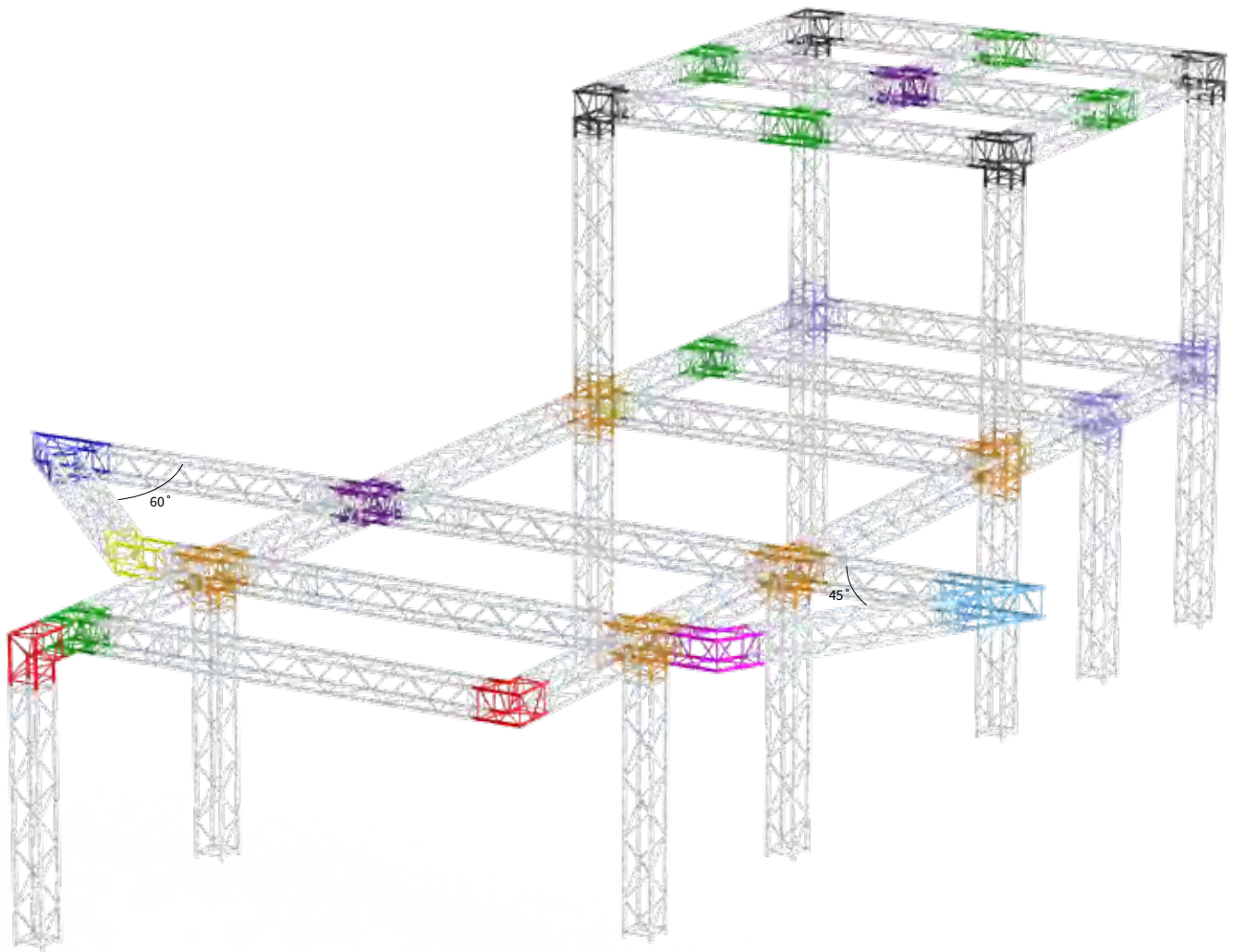

2way

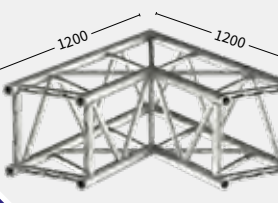
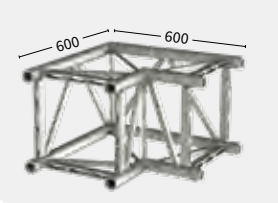
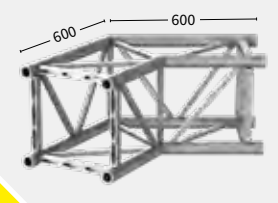
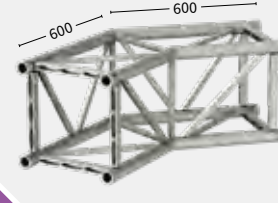
<p>TPM39S-C201 139501</p> <p>45° 12.3 kg</p> 	<p>TPM39S-C202 139502</p> <p>60° 14.6 kg</p> 	<p>TPM39S-C203 139503</p> <p>90° 8.6 kg</p> 
<p>TPM39S-C204 139504</p> <p>120° 9.3 kg</p> 	<p>TPM39S-C205 139505</p> <p>135° 9.6 kg</p> 	

3way

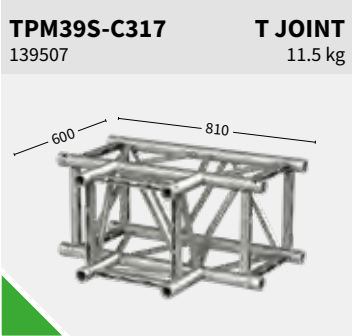
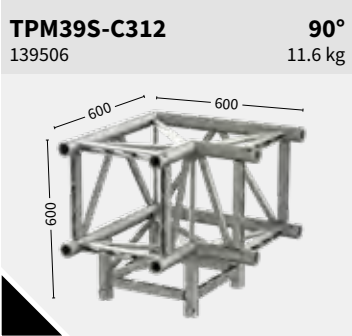

4way

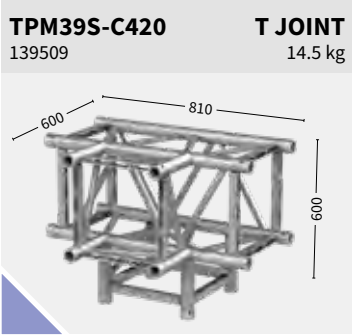
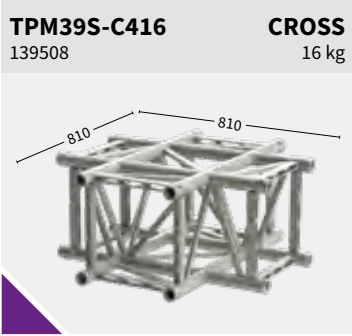

5way

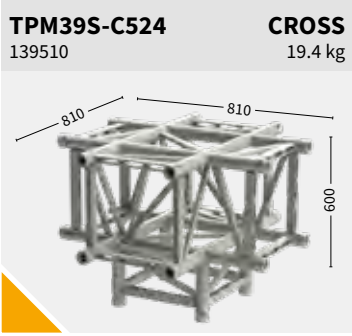

Box

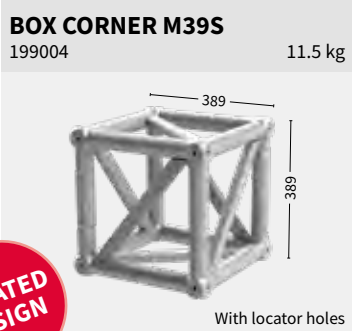

UPDATED DESIGN

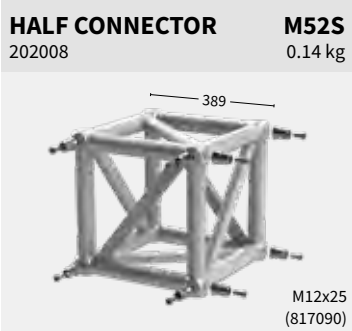





TPM39S Circles

● 48.3 x 3 mm



• Subject to tolerance, because product is 100% handmade.





TPM39S Circle part

-  6.3 kg/m
-  M
-  ALU/BLACK
-  ((RFID))
READY
-  P.136

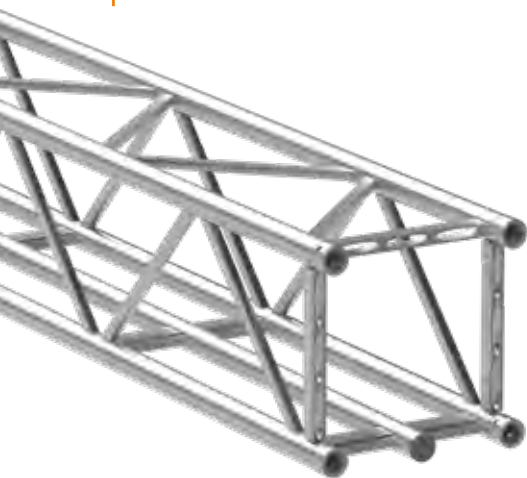
Code	∅ Diameter	Angle	Parts/Circle
140501	2 m	90	4
140502	3 m	90	4
140503	4 m	90	4
140504	5 m	90	4
140505	6 m	45	8
140506	8 m	45	8
140507	10 m	30	8
140508	10 m	45	12

TPM39S Middle Beam



-  7.9 kg/m
-  M
-  ALU/BLACK
-  ((RFID))
READY
-  P.136

TPM39S Middle Beam

Code	Length
143502	100 cm
143504	200 cm
143506	300 cm

48.3 x 3 mm

TPM39RP Length Square

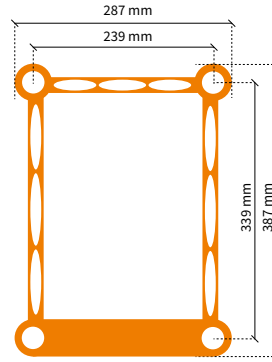

TPM39RP

Code	Length
144501	21 cm
144502	25 cm
144503	29 cm
144504	50 cm
144505	71 cm
144506	100 cm
144507	150 cm
144508	200 cm
144509	250 cm
144510	300 cm

6.9 kg/m ((RFID) READY)
 M P.136
 ALU/BLACK

Load table M39RP

Span	CPL	Deflection	2 x load	Deflection	3 x load	Deflection	4 x load	Deflection	UDL	Deflection
m	kg	mm	kg	mm	kg	mm	kg	mm	kg/m	mm
2.0	3054.3	2	1527.2	3	1018.1	3	763.6	3	1527.2	3
4.0	1840.9	9	1275.3	12	1014.0	11	760.5	12	760.5	12
6.0	1329.0	21	916.4	27	728.4	25	570.3	27	504.9	26
8.0	1035.1	38	727.1	48	555.5	45	441.3	48	299.2	47
10.0	843.3	59	600.0	75	446.5	70	358.0	75	189.2	73
12.0	707.5	85	508.3	108	371.1	100	299.6	108	129.5	106
14.0	605.7	115	438.7	147	315.5	137	256.0	147	93.5	144
16.0	526.1	150	383.7	192	272.5	179	222.1	192	70.1	188
20.0	408.4	235	301.6	300	209.8	279	172.2	300	42.6	294

Cantilever load

Span	1 x Load	Deflection	UDL	Deflection
m	kg	mm	kg/m	mm
0.5	1531.8	0	3060.6	0.1
1.0	1530.3	0.7	1527.2	0.6
1.5	1149.3	2.8	1016.0	1.9
2.0	918.3	7.1	760.5	4.4
2.5	770.0	14.6	535.7	7.6
3.0	662.0	26.1	380.2	11.3
3.5	579.7	42.4	287.3	15.9
4.0	514.9	64.4	226.6	21.6

Multiple supported span

Span	CPL	Deflection	2 x Load	Deflection	UDL	Deflection
m	kg	mm	kg	mm	kg/m	mm
2.0	2219.1	0	1139.5	0	1220.5	0.3
4.0	2183.8	4	1128.7	3	607.1	2.4
6.0	1542.7	9	858.2	8	367.7	7.5
8.0	1234.4	17	679.4	15	213.6	13.7
10.0	1023.3	28	565.0	25	143.5	22.4
12.0	868.9	40	480.8	36	102.5	33.2
14.0	750.3	55	415.9	50	76.4	45.9
16.0	655.9	72	364.1	65	58.8	60.3
20.0	513.4	110	285.6	100	37.2	103.6

Find complete loading tables on SIXTY82.nl

All loading data is based on calculations per EN-1999-1-1 and the following assumptions:

- Static loads only.
- Spans supported or suspended at both ends.
- Triangle trusses solely used apex-up, apex-down.
- 2 chords truss to be placed upright, supported from top chord and loaded from bottom chord.
- Truss spans can be constructed of elements of different length.

- Interaction between bending moment and shear force considered.
- Self-weight of truss is already considered.
- Assembled truss systems need an individual structural calculation. Please contact SIXTY82 or a structural engineer.
- Read the manual before use.
- Higher loading can be allowed depending on the truss configuration.

TPM39 Accessories

BASE PLATE M39T

211005

1.63 kg

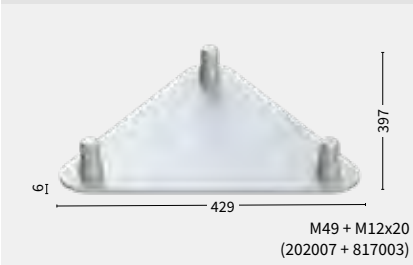

BASE PLATE M39S

211006

2.92 kg



LIFTING BRACKET M39S

212002

2.6 kg

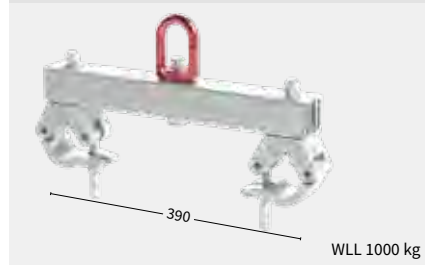

HANG-ON82 M39 TO M29S-T

251005

11.72 kg

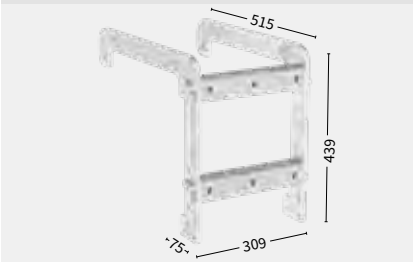

HANG-ON82 M39 TO M39S-T

251006

13.1 kg

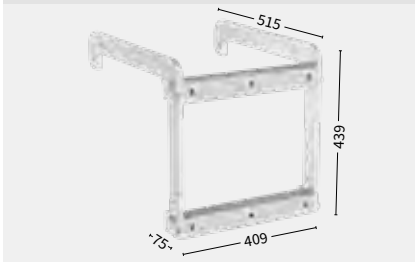

HANG-ON82 M39 TO M39L

251007

8.58 kg



WALL ADAPTER M39R

212006

4.35 kg



WALL ADAPTER M39S-T

212009

4.65 kg



BOOK CORNER M39S-T

198005

24.5 kg



LIFTINGPLATE M29S-T/M39R

Code	Finish
212010	Black
212011	Zinc



BOOK-FIX M39S-T

198006

4.43 kg

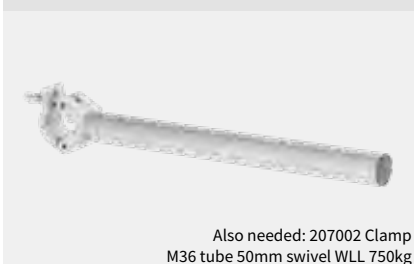

BASE PLATE STEEL M29/39S-T

Code	Finish	35 kg
211009	Black	
211010	Zinc	



BASE PLATE STEEL M29/M39S-T

Code	Finish	41 kg
211011	Black	
211012	Zinc	





WHY HANG-ON82?

- Alternative for the T-joint
- Flexible in use: can be used on every point in the grid
- Easy to use and assemble
- Can be used in conjunction with box corners and weld corners (spacers or special truss length needed)
- Can be used for ladder, triangle and square truss
- Natural and black finish available
- Load capacity 900 KG

Spare parts

1	202008	Half connector M52S	M series
2	817008	Bolt M12x25 Low head	M series
3	251008	Hang-on82 Spacer 30 mm	M series
4	817025	Bolt M12x60 Low head	M series

Safety

1 x 251014	Hang-on82 safety
2 x 817002	Nut self locking M12 DIN985
2 x 817005	Washer M12 Spring DIN127B
2 x 817006	Bolt M12x035 DIN933

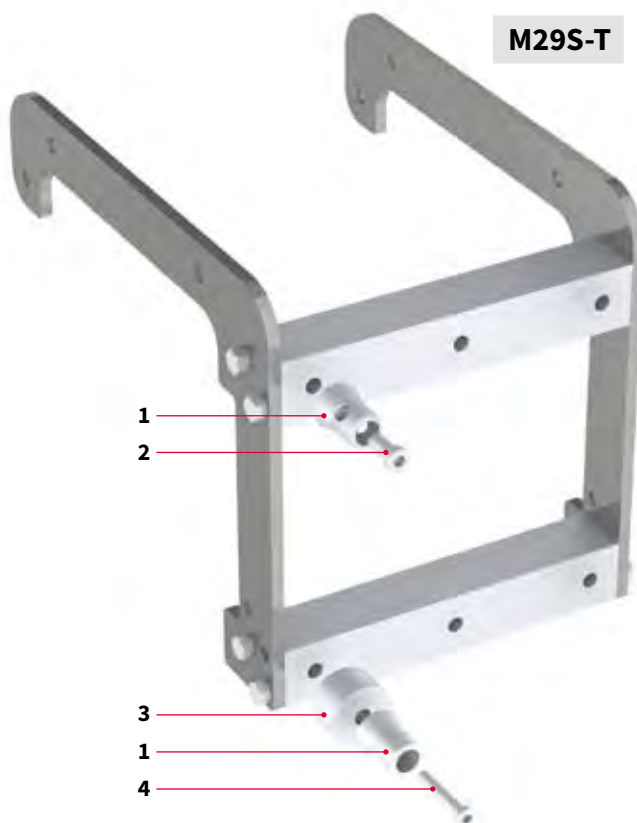

<p>M29 to M29S-T 251003 10.2 kg</p>	<p>M29 to M29L 251004 7.06 kg</p>	<p>M39 to M29S-T 251005 11.72 kg</p>
<p>M39 to M39S-T 251006 13.1 kg</p>	<p>M39 to M39L 251007 8.58 kg</p>	<p>HANG-ON82 SAFETY 251014 0.2 kg</p>

The design of this product is intellectually protected.

Hang-on82 in use

- 1 The grid is built with **weld corners**: the hang-on needs to be assembled with 30 mm spacers, and an extra piece of 210 mm (or 710 mm) truss needs to be used in the span (spare parts 1, 3 and 4).
- 2 The grid is built with **box corners with M51 receivers** (75 mm): the hang-on needs to be assembled with M52S connectors, and the same length of truss can be used for the span as is used in the grid (spare parts 1 and 2).
- 3 The grid is built with **box corners with M52S connectors**: the hang-on needs to be assembled with spacers, and an extra piece of 290 mm truss needs to be used in the span (spare parts 1, 3 and 4).

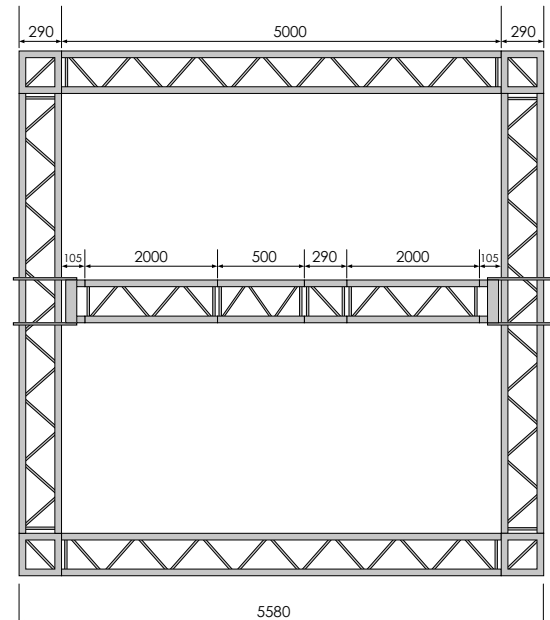
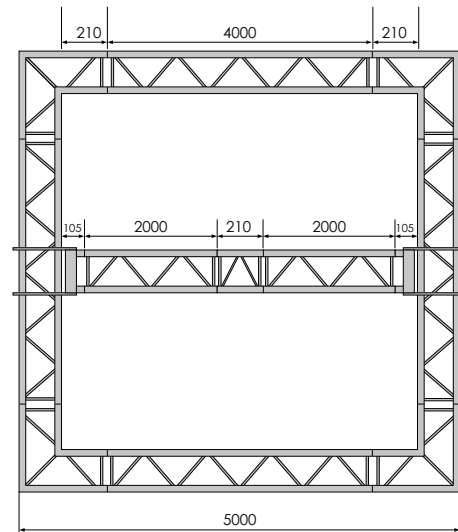
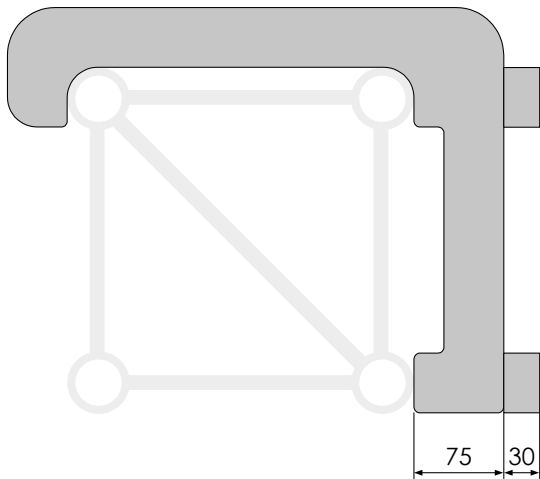

Scan the QR-Code
to watch the Hang-on82 technical video

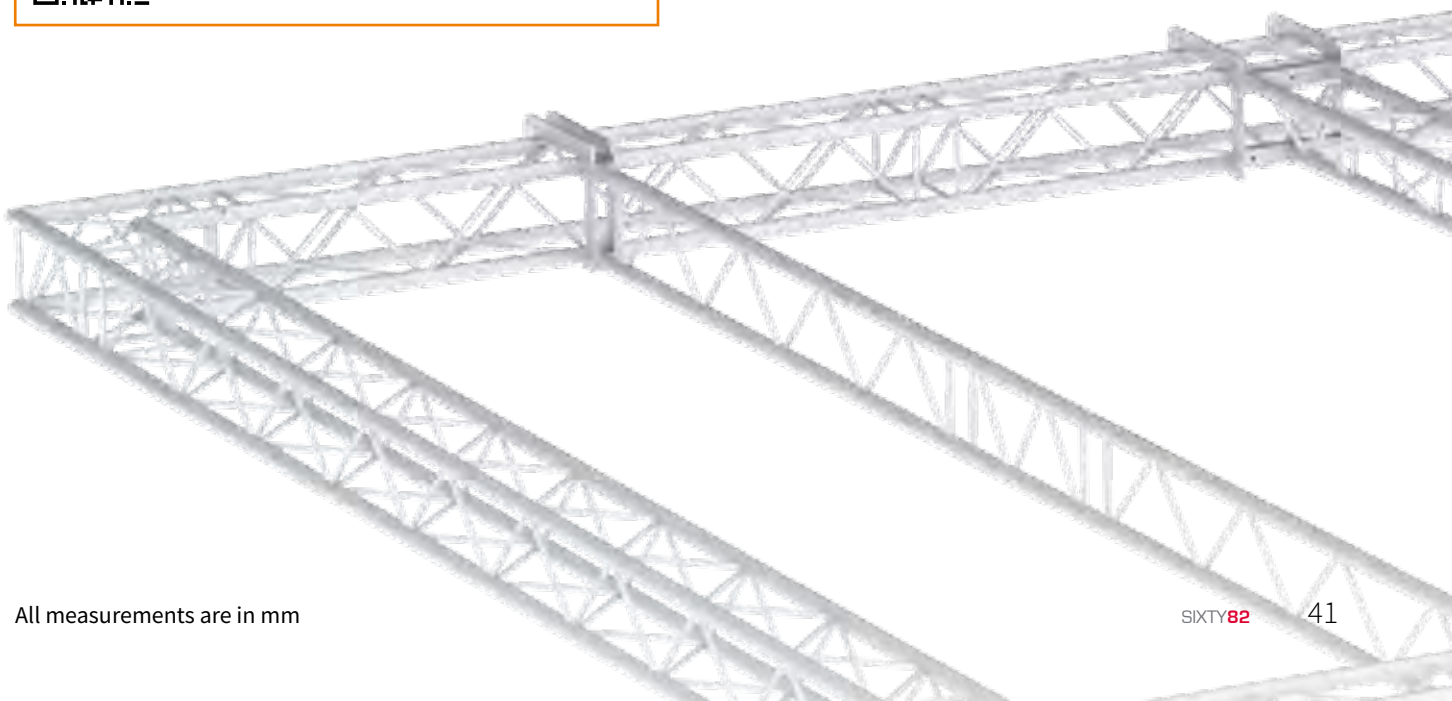

M Wall adapter82

WHY WALL ADAPTER82?

- Unique design
- The width is the same as the truss
- Adjustable position of clamps
- Can be used upright and upside down
- Suitable for triangle, square and rectangular shaped truss
- Can be positioned on an angle
- Suitable for M39R / M29S-T and M39S-T
- Load capacity 500 KG**

WALL ADAPTER M39R / M29S-T

212006

4.35 kg

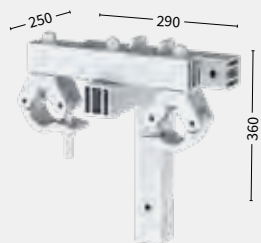

WALL ADAPTER M39S-T

212009

4.65 kg

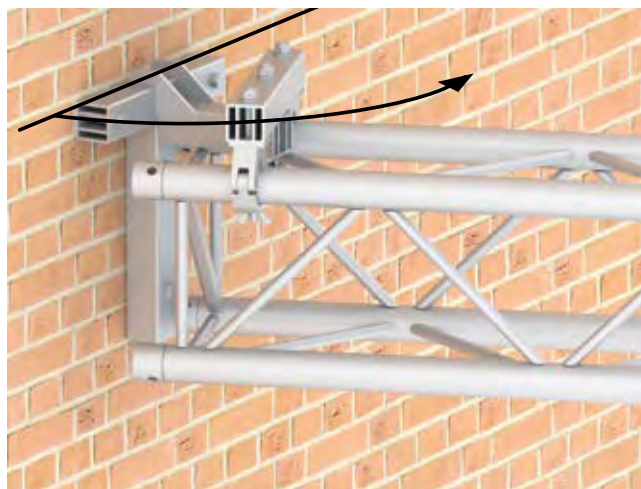
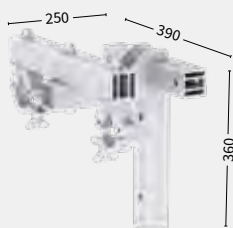

* Connection materials for the wall are not included.

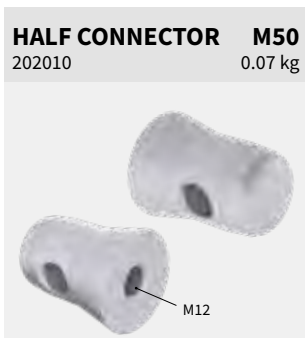

SPACER

Code	Length	Weight
202011	2 mm	0.16 kg
202027	5 mm	0.18 kg
202012	10 mm	0.2 kg
202013	20 mm	0.25 kg
202014	30 mm	0.3 kg
202015	40 mm	0.36 kg
202016	50 mm	0.41 kg

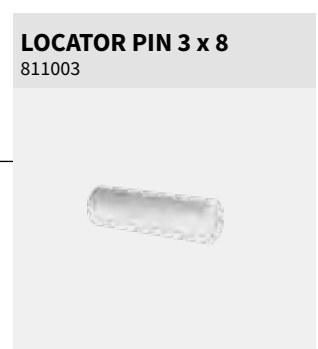
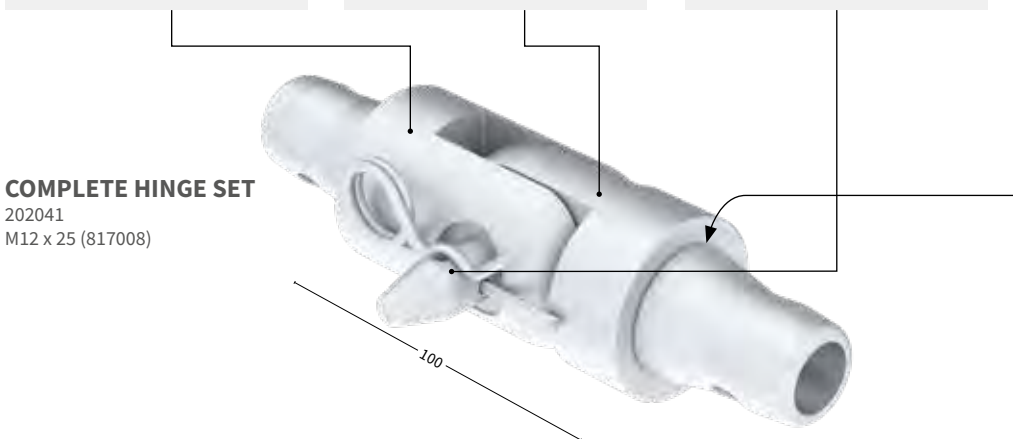

All measurements are in mm



Length

Square 46

Corners

Square 47

Circle

Square 47

Middle Beam

Square 47

Accessories

48

Accessories L Series

49

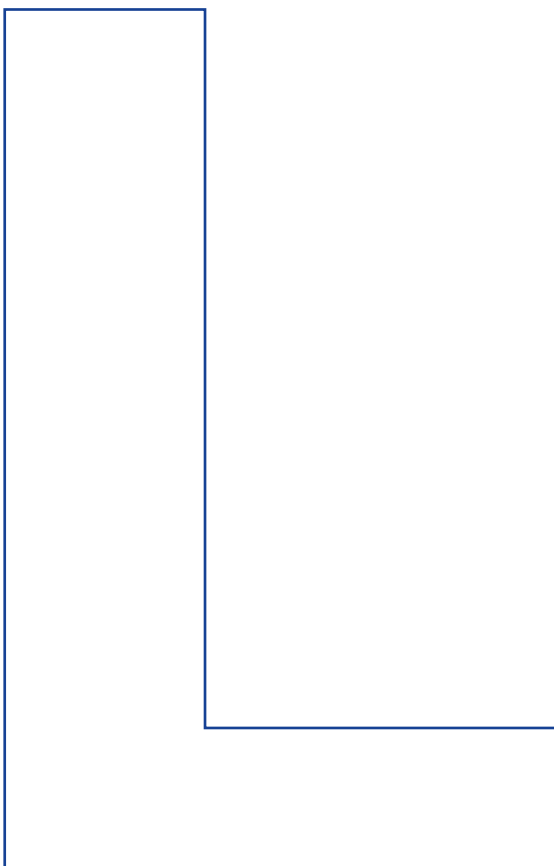

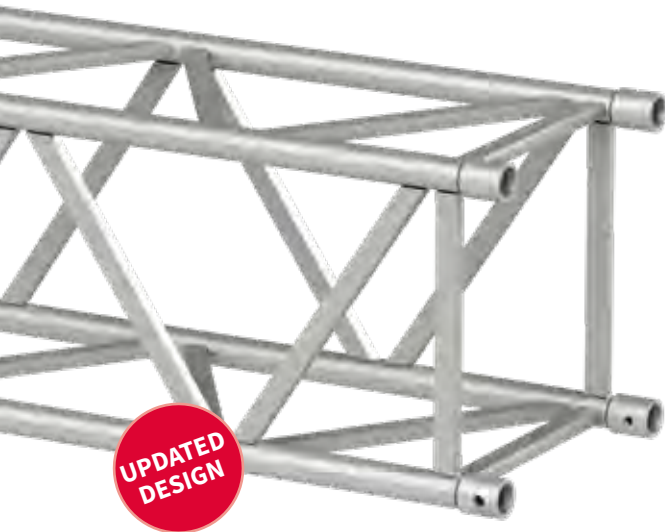

UPDATED DESIGN

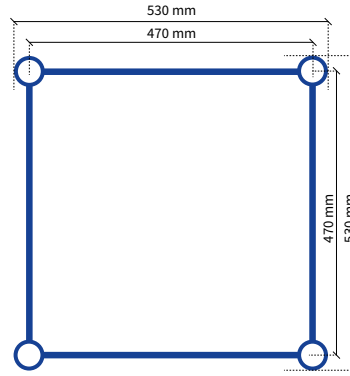

- 15 kg/m
- (RFID) READY
- L
- P.136
- ALU/BLACK

L52S

Code	Length
161001	50 cm
161002	60 cm
161003	80 cm
161004	100 cm
161005	120 cm
161006	150 cm
161007	200 cm
161008	240 cm
161009	250 cm
161010	300 cm
161012	400 cm

Load table L52S

Span m	CPL kg	Deflection mm	2 x load kg	Deflection mm	3 x load kg	Deflection mm	4 x load kg	Deflection mm	UDL kg/m	Deflection mm
2.0	4846.8	2	3066.8	2	2279.7	2	1709.8	2	3419.5	2
6.0	2255.1	15	1518.9	19	1271.6	17	976.2	19	960.7	18
10.0	1480.1	41	1033.6	52	799.5	48	632.2	52	336.6	51
14.0	1094.3	80	779.3	102	576.5	95	464.5	102	164.7	100
18.0	845.5	132	621.1	169	422.8	157	352.3	169	93.9	165
20.0	733.6	163	550.2	208	366.8	193	305.7	208	73.4	204
22.0	639.4	197	479.6	252	319.7	234	266.4	252	58.1	246
24.0	558.6	235	418.9	300	279.3	278	232.7	300	46.5	293
26.0	487.9	275	365.9	352	243.9	327	203.3	352	37.5	344

Cantilever load

Span m	1 x Load kg	Deflection mm	UDL kg/m	Deflection mm
0.5	3430.3	0	6853.5	0
1.0	2420.6	1	3419.5	1
1.5	1839.4	2	1919.4	1
2.0	1518.7	5	1208.5	3
2.5	1292.6	10	824.0	5
3.0	1124.5	17	611.5	7
3.5	994.6	28	473.7	10
4.0	891.0	43	377.9	14

Multiple supported span

Span m	CPL kg	Deflection mm	2 x Load kg	Deflection mm	UDL kg/m	Deflection mm
2.0	4891.4	0	2565.3	0	2732.7	0
6.0	2526.4	6	1373.7	5	565.5	4
10.0	1749.5	18	956.9	16	240.8	15
14.0	1327.8	38	726.3	34	133.1	31
18.0	1059.6	64	578.2	57	83.7	53
20.0	957.9	80	522.0	71	68.4	73
22.0	854.9	94	473.9	85	56.7	107
24.0	746.7	107	432.1	101	46.5	151
26.0	652.3	119	395.4	118	37.5	208

Find complete loading tables on SIXTY82.nl

All loading data is based on calculations per EN-1999-1-1 and the following assumptions:

- Static loads only.
- Spans supported or suspended at both ends.
- Triangle trusses solely used apex-up, apex-down.
- 2 chords truss to be placed upright, supported from top chord and loaded from bottom chord.
- Truss spans can be constructed of elements of different length.

- Interaction between bending moment and shear force considered.
- Self-weight of truss is already considered.
- Assembled truss systems need an individual structural calculation. Please contact SIXTY82 or a structural engineer.
- Read the manual before use.
- Higher loading can be allowed depending on the truss configuration.

● 50 x 4 mm

L52 Corners

BOX CORNER L52S

199009

27.4 kg



UPDATED DESIGN

HALF CONNECTOR

203024

L52S

0.27 kg



M16x30
(818035)

RECEIVER

203008

L51

0.35 kg

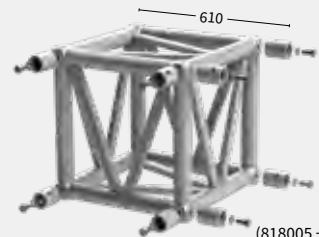

M16x35
(818005 + 818006)

L52 Circles

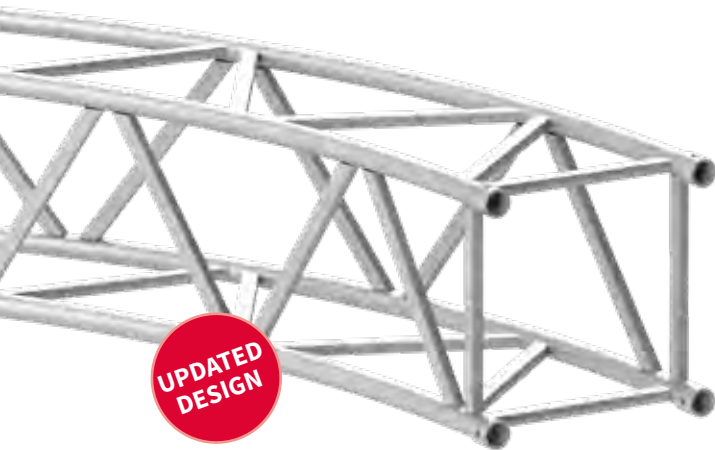

UPDATED DESIGN

• Subject to tolerance, because product is 100% handmade.

L52S Circle part

- 15 kg/m
- L
- ALU/BLACK
- ((RFID))
READY
- P.136

Code	∅ Diameter	Angle	Parts/Circle
163001	3 m	90	4
163002	4 m	90	4
163003	5 m	90	4
163004	6 m	90	4
163005	8 m	45	8
163006	10 m	30	12

L52 Middle Beam

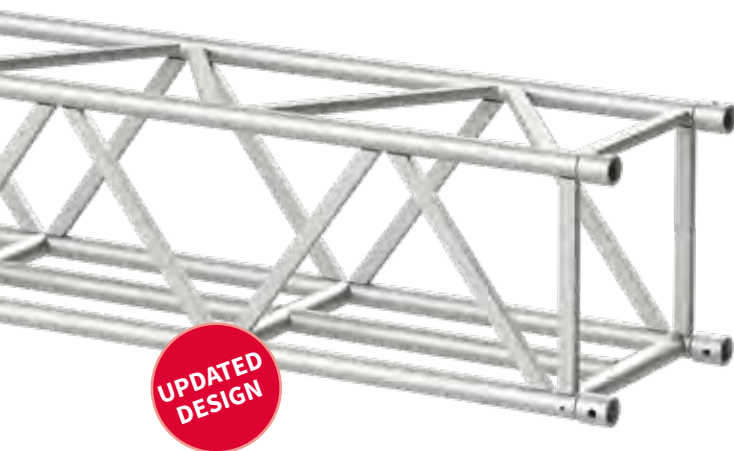

UPDATED DESIGN

- 12.6 kg/m
- L
- ALU/BLACK
- ((RFID))
READY
- P.136

L52 Middle Beam

Code	Length
166004	100 cm
166007	200 cm
166010	300 cm

L52 Accessories

BASE PLATE L52S

211007

24.43 kg

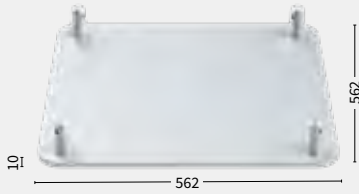

L02 + M16x40
(203002 + 818001)

LIFTING BRACKET L52S

212005

4.72 kg

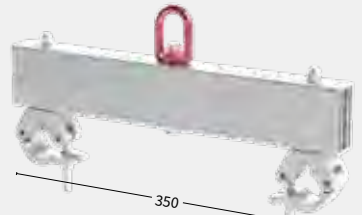

WLL 1000 kg



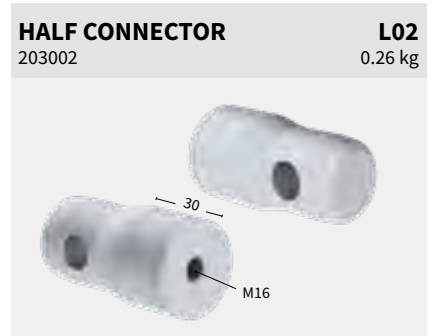
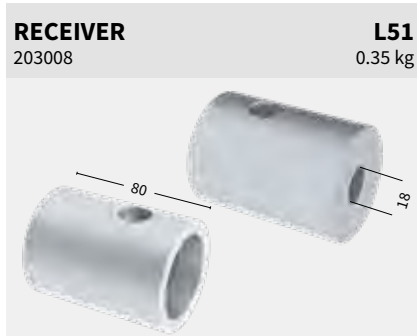
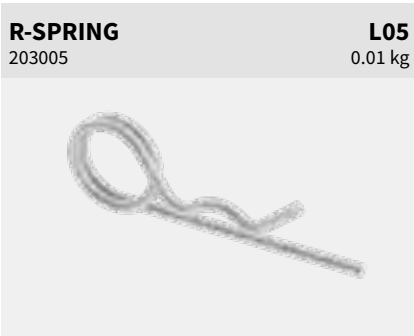
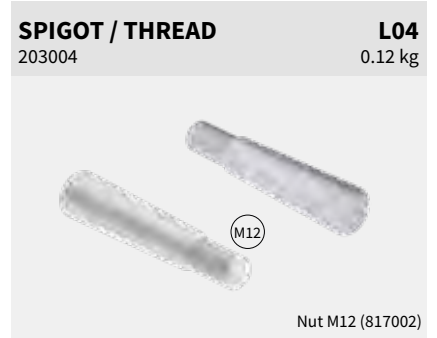
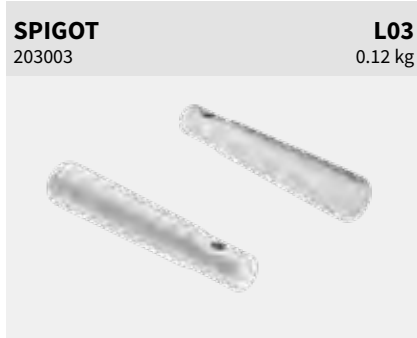

SPACER

Code	Length	Weight
203009	2 mm	0.3 kg
203010	5 mm	0.33 kg
203011	10 mm	0.36 kg
203012	20 mm	0.44 kg
203013	30 mm	0.51 kg
203014	40 mm	0.59 kg
203015	50 mm	0.67 kg





Length

Rectangle	52
-----------	----

Corners

Rectangle	53
-----------	----

Accessories XL Series	53
------------------------------	----



XL101R Length Rectangle

60 x 6 mm

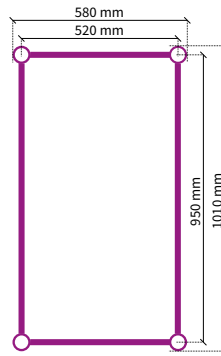

XL101R

Code	Length
171001	80 cm
171002	100 cm
171003	120 cm
171004	200 cm
171005	240 cm
171006	250 cm
171007	300 cm
171009	400 cm
171011	480 cm

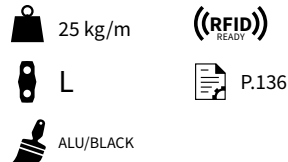

Load table XL101R

Span m	CPL kg	Deflection mm	2 x load kg	Deflection mm	3 x load kg	Deflection mm	4 x load kg	Deflection mm	UDL kg/m	Deflection mm
4.0	7034.6	4	4261.0	5	3139.5	4	2500.8	5	2993.4	5
12.0	3549.8	33	2322.7	42	1909.9	39	1549.9	42	808.3	41
16.0	2820.5	58	1894.7	74	1592.0	69	1218.3	74	444.8	73
20.0	2309.7	91	1582.3	116	1273.9	108	990.4	116	276.6	114
24.0	1926.6	131	1341.1	168	1044.8	156	821.8	168	185.2	164
28.0	1624.7	179	1146.9	228	869.5	212	690.4	228	130.1	223
32.0	1377.4	233	984.9	298	729.4	277	583.7	298	94.3	291
36.0	1168.6	295	846.1	377	613.3	350	494.3	377	69.8	369
40.0	987.9	364	724.2	465	514.5	432	417.4	465	52.3	455

Cantilever load

Span m	1 x Load kg	Deflection mm	UDL kg/m	Deflection mm
0.5	5483.6	0	11737.1	0
1.0	4712.9	0	5472.8	0
1.5	4047.9	1	3382.1	0
2.0	3500.7	2	2346.6	1
2.5	3058.4	4	1736.7	2
3.0	2771.9	7	1340.4	3
3.5	2532.3	12	1066.0	4
4.0	2328.6	18	867.2	5

Multiple supported span

Span m	CPL kg	Deflection mm	2 x Load kg	Deflection mm	UDL kg/m	Deflection mm
4.0	6638.8	1	3518.0	1	1991.3	1
12.0	3763.9	11	2037.5	10	409.3	8
16.0	3090.1	22	1683.6	19	257.1	17
20.0	2584.5	35	1415.0	31	175.2	28
24.0	2186.3	51	1201.7	46	125.3	53
28.0	1861.0	70	1026.1	63	92.5	98
32.0	1587.5	89	877.6	80	69.8	167
36.0	1352.0	107	749.2	97	53.3	267
40.0	1145.4	125	636.0	113	41.0	400

Find complete loading tables on SIXTY82.nl

All loading data is based on calculations per EN-1999-1-1 and the following assumptions:

- Static loads only.
- Spans supported or suspended at both ends.
- Triangle trusses solely used apex-up, apex-down.
- 2 chords truss to be placed upright, supported from top chord and loaded from bottom chord.
- Truss spans can be constructed of elements of different length.

- Interaction between bending moment and shear force considered.
- Self-weight of truss is already considered.
- Assembled truss systems need an individual structural calculation. Please contact SIXTY82 or a structural engineer.
- Read the manual before use.
- Higher loading can be allowed depending on the truss configuration.

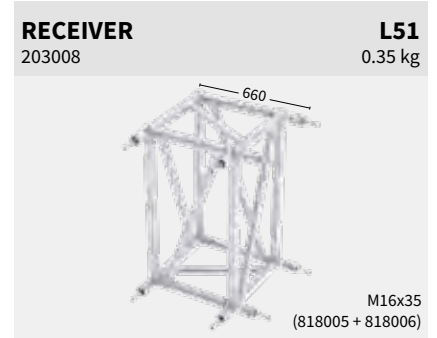
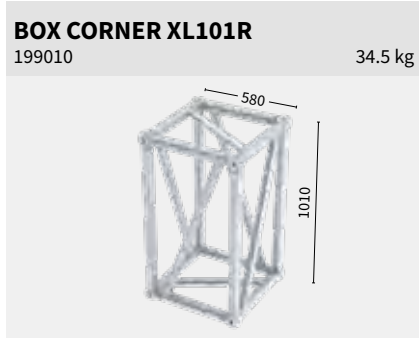

Accessories XL Series

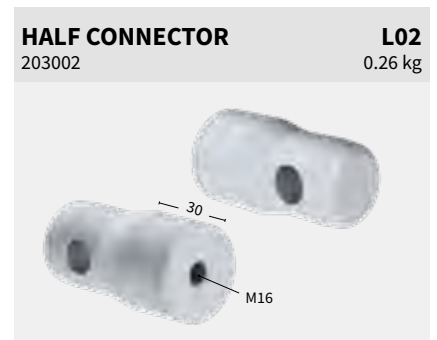
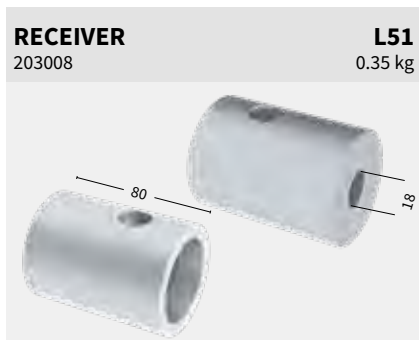
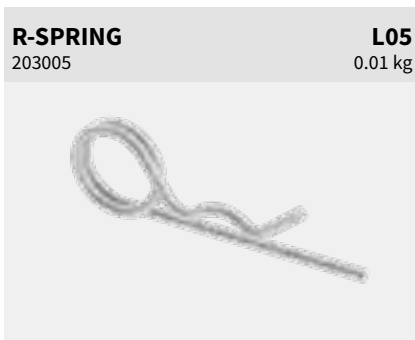
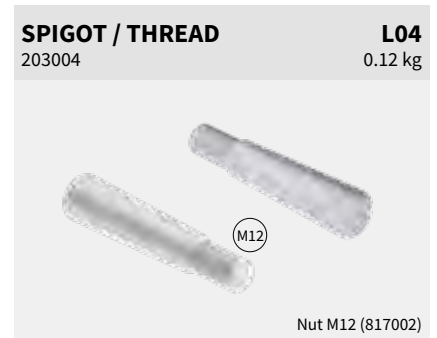
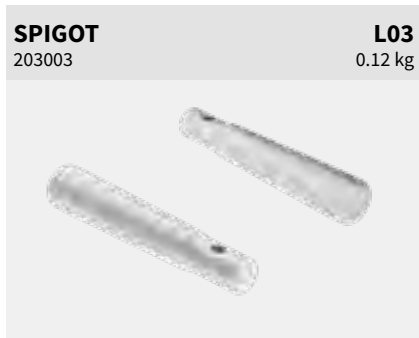

SPACER

Code	Length	Weight
203009	2 mm	0.3 kg
203010	5 mm	0.33 kg
203011	10 mm	0.36 kg
203012	20 mm	0.44 kg
203013	30 mm	0.51 kg
203014	40 mm	0.59 kg
203015	50 mm	0.67 kg

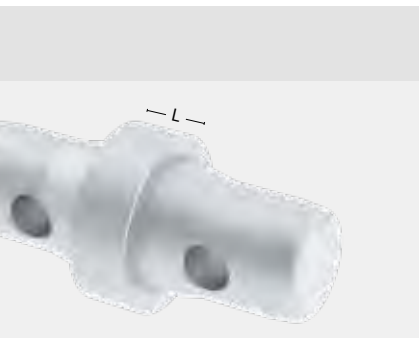





SIXTY82™

ALPHA⁸²

MODULAR TRUSS SYSTEM



WORLDWIDE PATENT

Opening new doors

ALPHA82 is a brand-new patented truss system that you can configure to the job ahead. The unique ALPHA connectors can be connected to expertly designed ALPHA ladder trusses (sizes L39, L52 and XL101) to form a 3D truss with similar strength compared to standard trusses with the same dimensions.

The ALPHA connector contains M12 size slots on all 4 sides enabling you to connect accessories such as lifting eyes, clamps, brackets, curtain tracks, trolley beams, braces and/or machinery.

Available in **three standard heights**

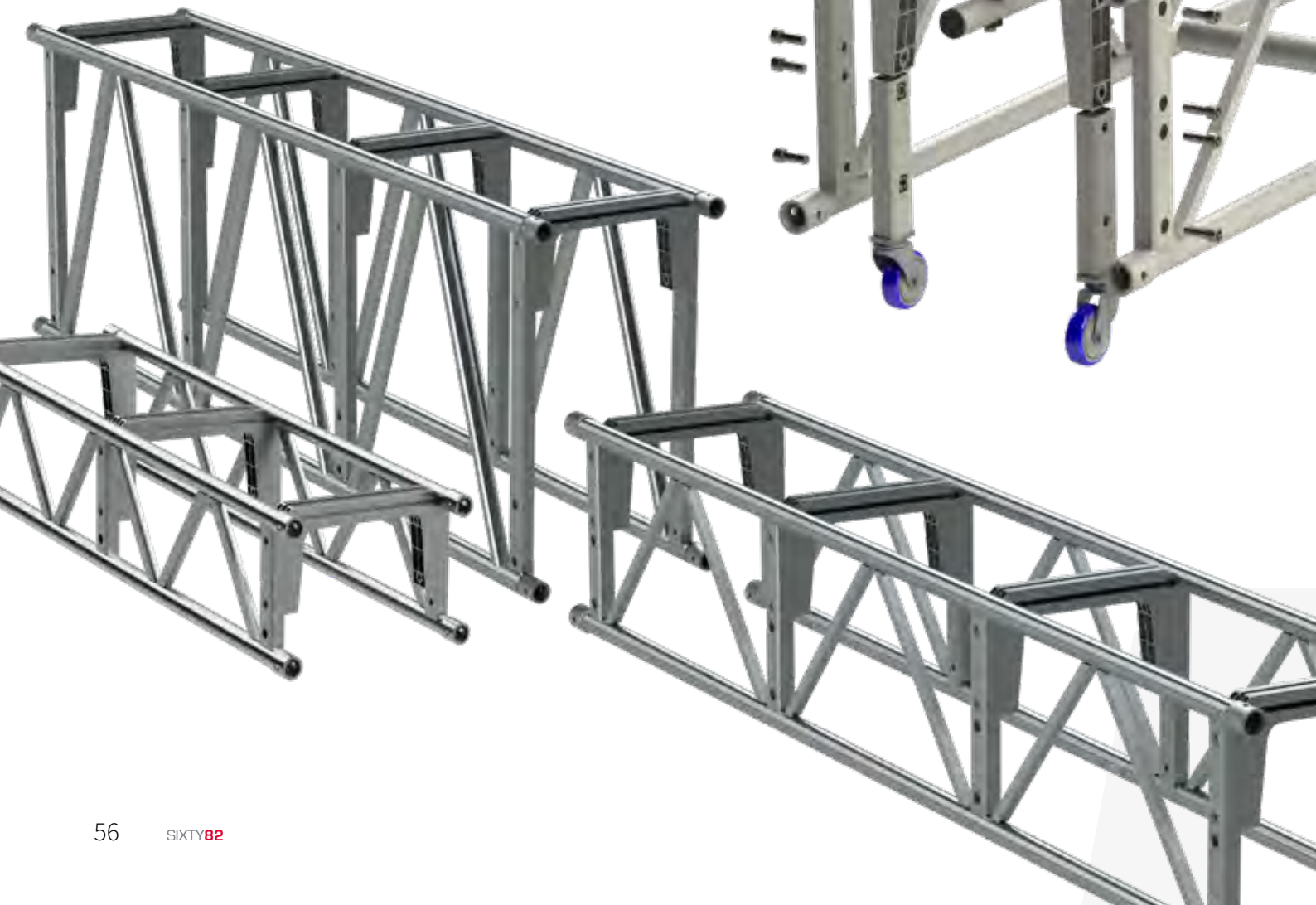

Endless possibilities

Once delivered, you can assemble, configure, and let your creativity run free, using either our 'standard' ALPHA connector or your own configuration to create the shape you need. You can easily adjust your 52 truss from 30 cm width up to 80 cm width with just a couple of bespoke ALPHA connectors and no further investment in truss parts. This results in a much more flexible inventory than your competitors, a lower storage cost due to less warehouse space and, ultimately, a better ROI.



L52 Single



XL101 Single



I Beam



Stackable Truss



L52 Vertical Stacked



XL101 Vertical Stacked

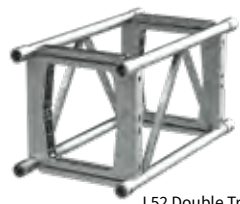

L52 Double Truss



Cable Trunk



L52 Rectangle



Wheel Bracket



60 mm Tube



Stacked L52 Truss

Loading capacity of the Alpha Modular Truss System

Trusses designed from the gamechanging **Alpha Modular Truss System** can have different sizes and shapes. To get an idea of the loading capacity of ALPHA trusses we highlight the **ALPHA L52S truss**. The load table shows loading data of a single span in a basic setup made from AMTS L52 ladders and AMTS Connectors L52S between the top chords only. The truss is open at the bottom.

Adding more ALPHA components to the configuration like horizontal diagonals, cross tubes or ALPHA connectors between the bottom chords will lead to an increase of the vertical and horizontal loading capacity.

Load table

Span m	CPL kg	Deflection mm	2 x load kg	Deflection mm	3 x load kg	Deflection mm	UDL kg/m	Deflection mm
3.0	2250	1	1687.5	2	1125	2	1500	2
6.0	2232	12	1674	15	1116	14	744	15
10.0	1500	36	1125	46	750	43	300	45
14.0	1120	74	840	95	560	88	160	93
18.0	738	104	553.5	133	369	123	82	130
20.0	650	125	487.5	160	325	149	65	157
22.0	561	144	420.8	184	280.5	171	51	180
24.0	528	176	396	225	264	209	44	220

Load Capacity Bolt Channel

Type of Bolt Head of Nut	Max Load
M12 Hexagon Bolt Head	600 kg
M12 Hexagon Nut Din 934	600 kg

Values given are for vertical loads only.

Allowable loadings are based on Eurocode EN 1999.

Higher loads are possible. E.g. when square nuts or bespoke inserts are used.

The maximum load shall also be checked in relation with the length of the span of the ALPHA joint.



Technical data

AMTS CONNECTOR

181001

L52S

2.2 kg



Bolt M16x045 DIN912

AMTS CONNECTOR L52 STACKABLE

181002

2.2 kg



Bolt M16x045 DIN912

AMTS CONNECTOR

181003

XL101

2.4 kg



Bolt M16x045 DIN912

AMTS L39 LADDER

Code	Length	Weight
182061	50 cm	4.6 kg
182062	100 cm	6.6 kg
182063	200 cm	11 kg
182065	240 cm	13 kg
182064	300 cm	15.5 kg

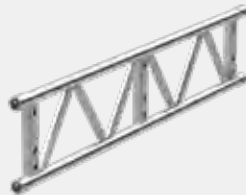

AMTS L52 LADDER

Code	Length	Weight
182001	50 cm	5.1 kg
182002	100 cm	7.1 kg
182003	200 cm	11.9 kg
182004	300 cm	16.7 kg

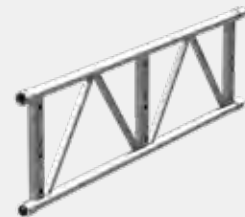

AMTS XL101 LADDER

Code	Length	Weight
182031	50 cm	8.5 kg
182032	100 cm	12.5 kg
182033	200 cm	21.9 kg
182034	300 cm	31.3 kg
182036	2 ft	
182037	4 ft	
182038	6 ft	
182039	8 ft	
182040	10 ft	



DIAGONAL TRUSS

2.4 kg

Code	Type	Length
183001	AMTS L52	100 cm
183002	AMTS L52	200 cm
183003	AMTS L52	300 cm
183004	AMTS XL101	100 cm
183005	AMTS XL101	200 cm
183006	AMTS XL101	300 cm



including accessoires

VERTICAL CONNECTOR TUBE

Code	Type	Weight
183010	AMTS L52S	1.6 kg
183011	AMTS XL101	3.5 kg



including accessoires

CROSS TUBE 60MM

Code	Type
183012	AMTS L52S
183013	AMTS XL101

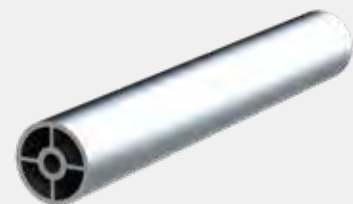

Bolt M16x045 DIN912

AMTS WHEEL BRACKET SINGLE

183014

1.9 kg



including accessoires



Scan the QR-Code
to watch the ALPHA82 video

ALPHA Pre-rig Truss

Introducing the **ALPHA82 Pre-rig Truss**. As a leading truss manufacturer, we understand the needs of the AV industry, which is why we've designed the **ALPHA82 Pre-rig Truss** to offer a convenient and efficient pre-rigged solution that can save time and effort during installation.

The **ALPHA82 Pre-rig Truss** is a modular truss system that can be easily configured and assembled to fit any venue or event space. The **ALPHA82 Pre-rig Truss** is designed with the **ALPHA connectors** that allow for easy attachment of various accessories, including lifting eyes, clamps, brackets, curtain tracks, trolley beams, braces, and machinery. This gives you the flexibility to add the fixtures and equipment that you need for your specific event.

To make installation even more effortless, we offer a foldable dolly that can be used to transport and set up the **ALPHA82 Pre-rig Truss**. The dolly is compact and easy to maneuver, making it ideal for events with tight deadlines or limited setup time.

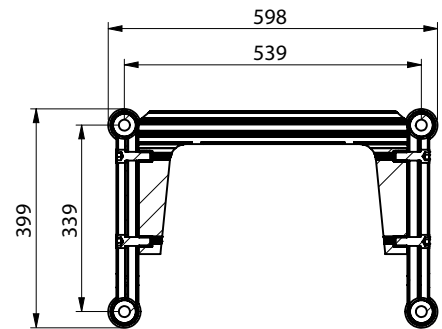
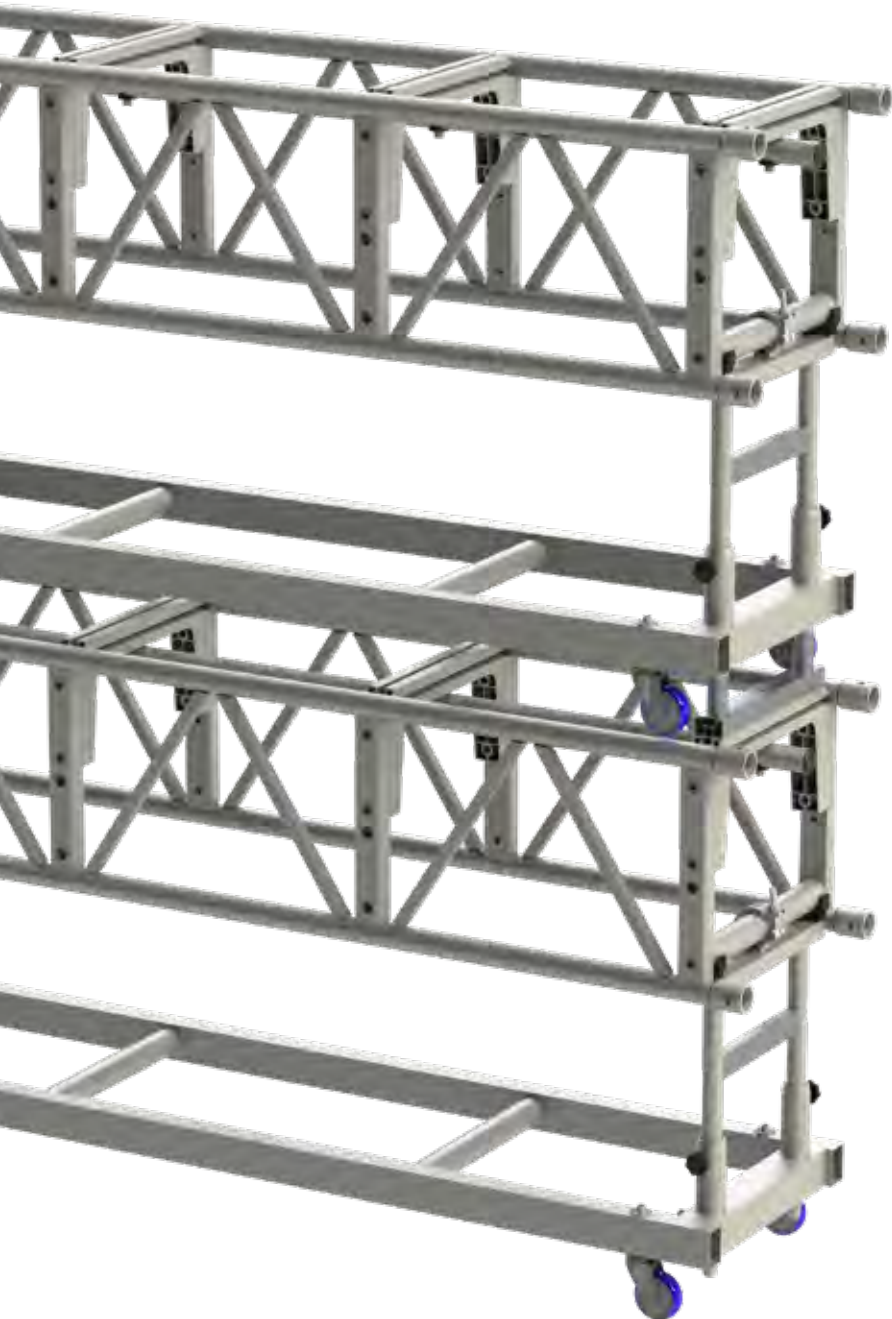

Alpha L39

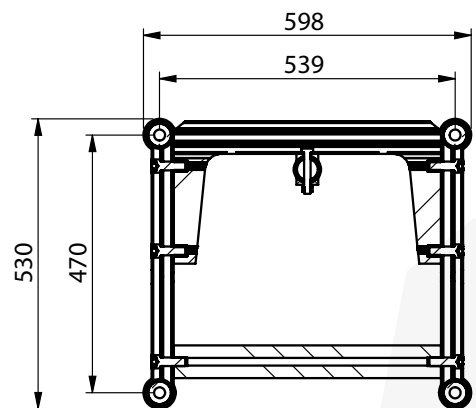

Alpha L52

AMTS PRE-RIG L39 LADDER 240cm 2
182065 13 kg



AMTS PRE-RIG L52 LADDER 240cm 2
182011 14.5kg



AMTS CONNECTOR PRE RIG 4
181005 2.5kg



AMTS MIDDLE TUBE 50X4 240cm 1
183029 4.32kg



AMTS PRE-RIG CROSS TUBE 60mm 2
183026 1.4kg



AMTS PRE-RIG DOLLY 240cm 1
183025 27.5kg



AMTS PRE-RIG STACKER 2
183030 1.5kg



AMTS MIDDLE TUBE BRACKET
183056

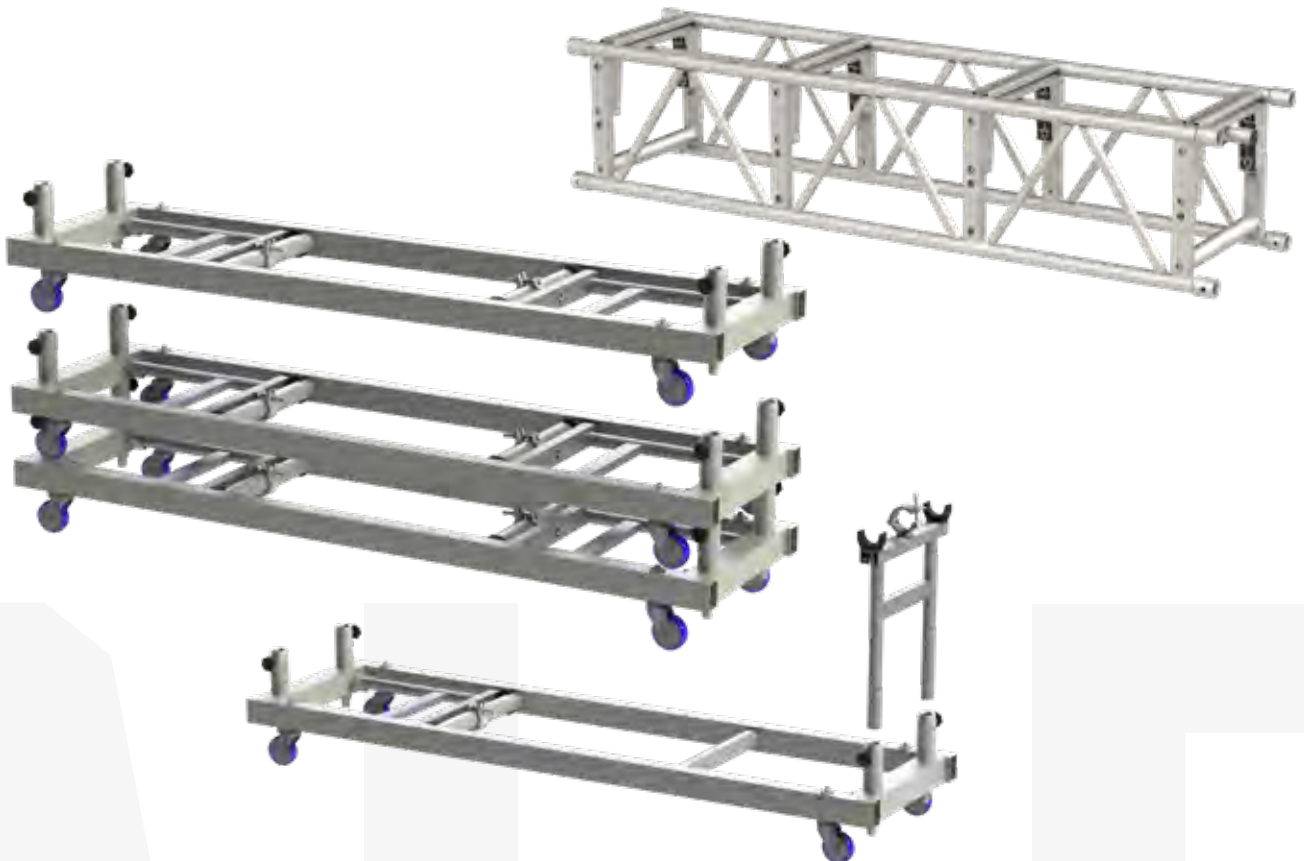

ALPHA82 LED

Introducing the ALPHA82 LED Adjuster, the latest innovation in our ALPHA truss series.

This advanced accessory enables precise leveling of large LED panel spans, ensuring flawless screen alignment. The adjusters are spaced in 50 cm increments for optimal flexibility and compatibility. For added convenience, users have the option to leave the LED spreader bars integrated within the ALPHA truss during transport, offering the potential to improve setup time significantly.

AMTS LED ADJUSTER SET

Code	Length
183051	50 cm
183052	100 cm
183053	200 cm
183054	240 cm
183055	300 cm

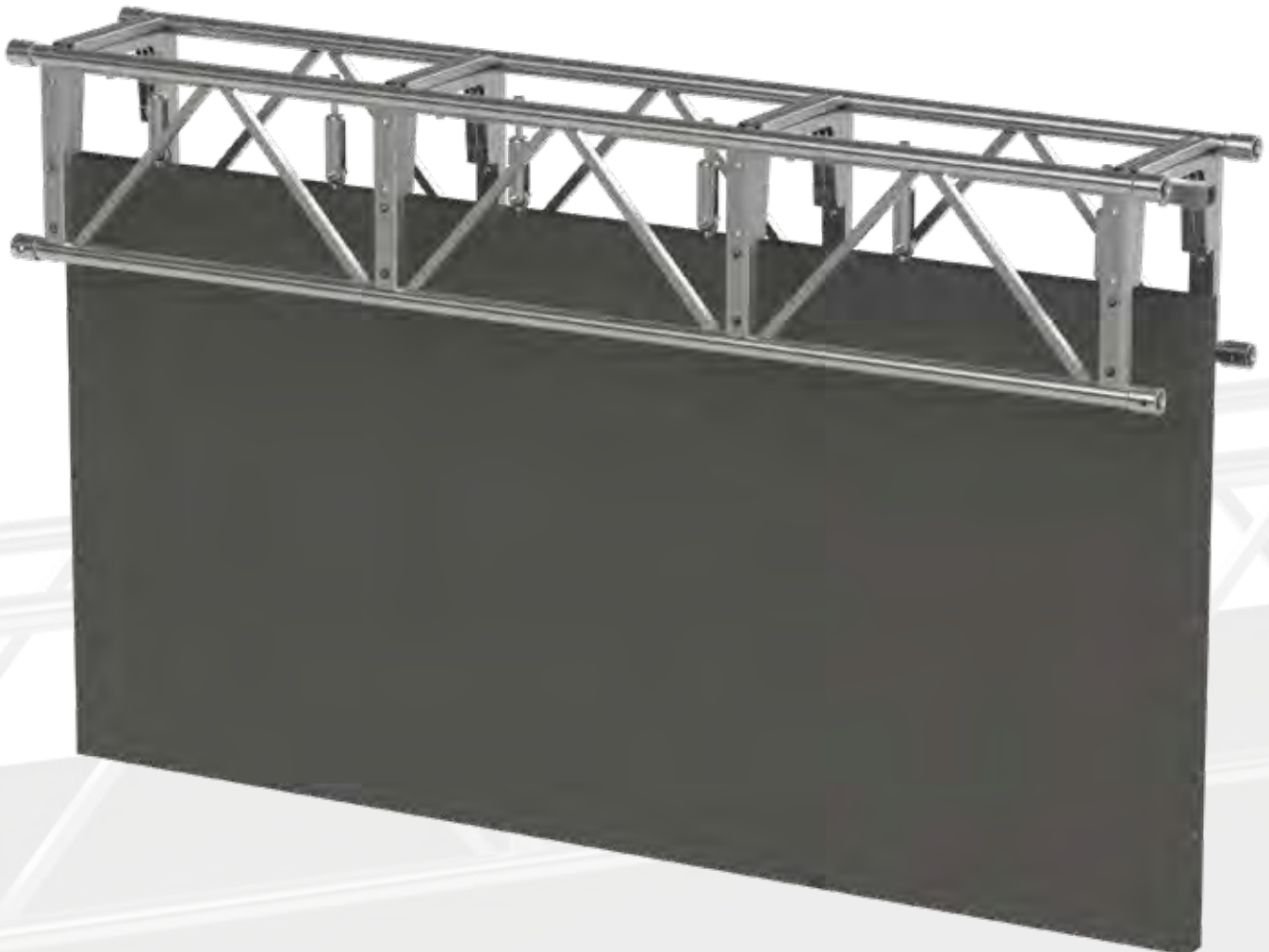

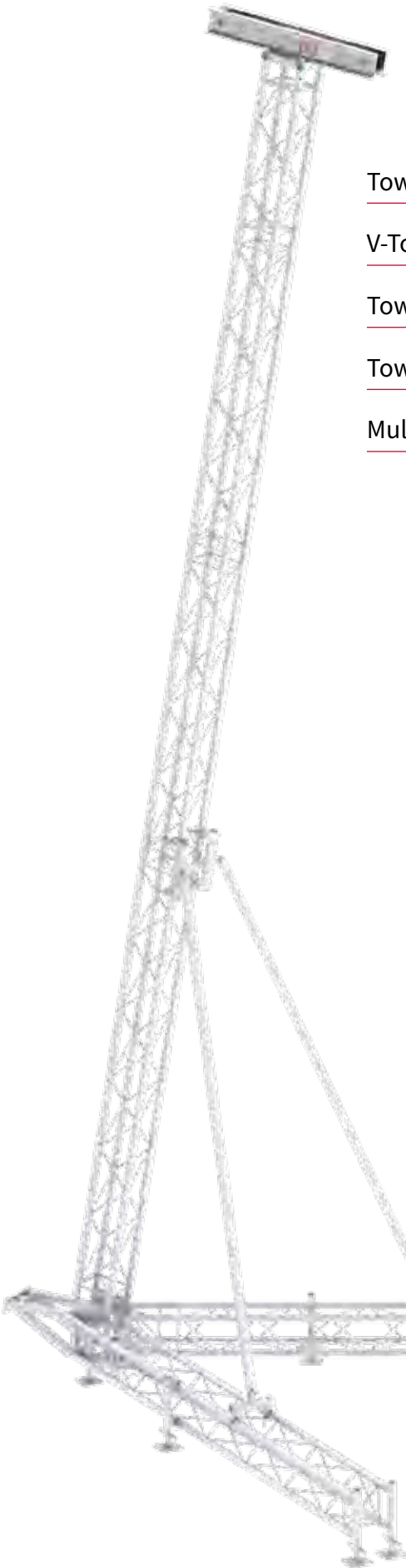

Tower Model M	64
V-Tower Model M	66
Tower Model L	68
Tower Model XL	70
Multibase Tower	72

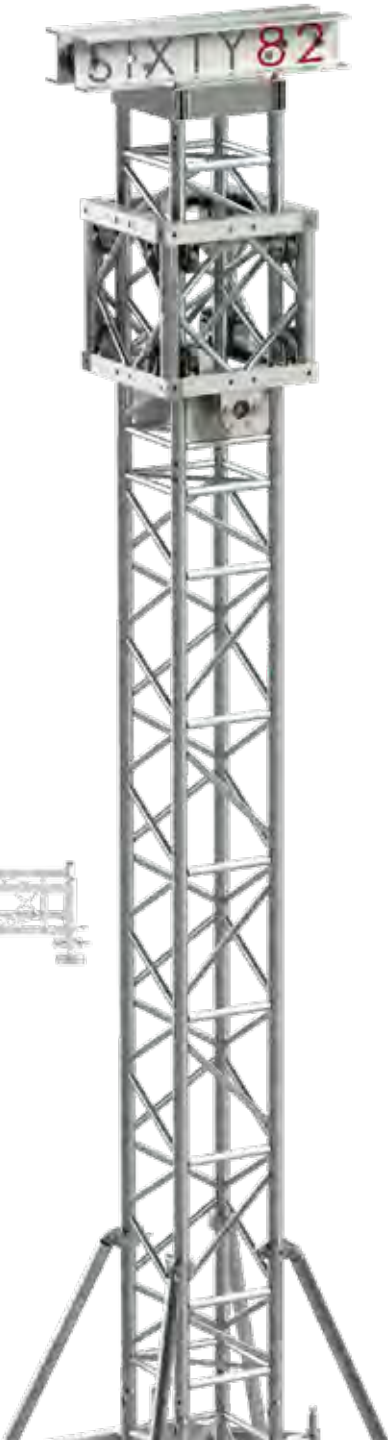



Tower Model M

HOW TO?

UNDERSTANDING TOWER LOADING

The following variables determine the allowable tower loading:

- Tower length
- Tower cross sectional dimensions
- Dimension of chords
- Method of restraining top and bottom of the tower
- Use of guy wires
- If the tower base is ballasted

Integrated deadhang: safe and fast

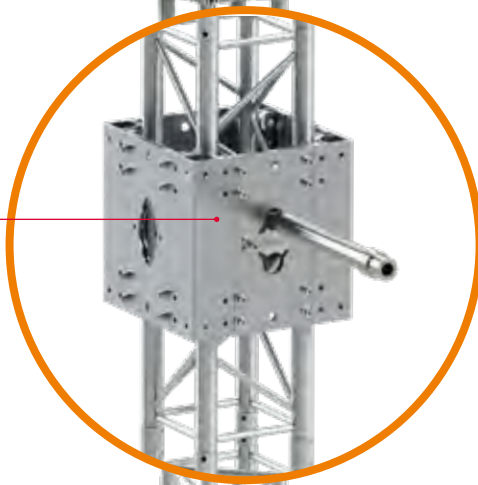

TPM29S Trussing Tower



Self-locking outrigger system: a unique feature of the Alu Base

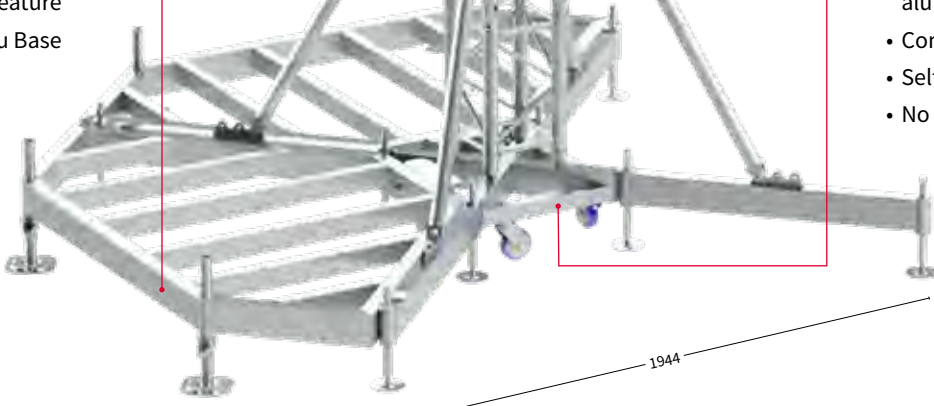

Alu Base:

- Lighter due to use of bespoke aluminium extrusions
- Compact design
- Self locking outrigger system
- No moving locking parts

1944

WHY SLEEVE BLOCK PLATED?

- Completely bolted to avoid weakening due to welding
- Lighter weight due to use of special alloys
- Integrated deadhang system
- Deadhang system restrains the sleeve block in 2 directions, therefore optimised for roof systems
- Radiused edges for ease of handling

SLEEVE BLOCK M29/M39 TM10
232001 25.2 kg

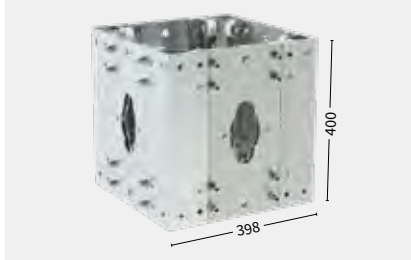

MOTOR BRACKET TM10
234003 6.47 kg

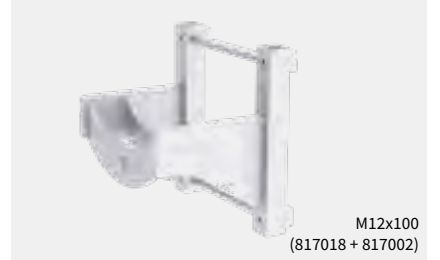

HORSE SHOE TM10
232006 0.31 kg



HEAD SECTION TM09
233001 7.3 kg

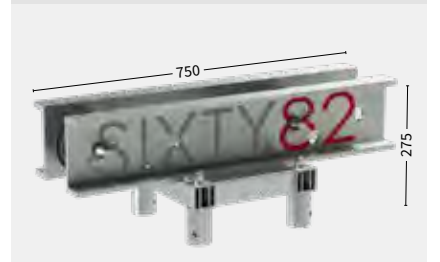

SAFE SYSTEM TPM29S TM10
232510 7.8 kg

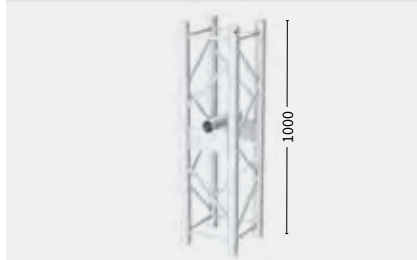

SAFE PIN M29S TM10
232011 4 kg



ALU BASE TM04
231001 12.9 kg

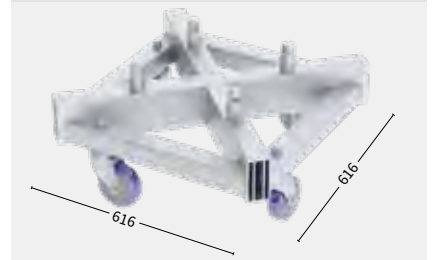

SHORT OUTRIGGER TM11
231002 3.1 kg



LONG OUTRIGGER TM12
231003 10.1 kg

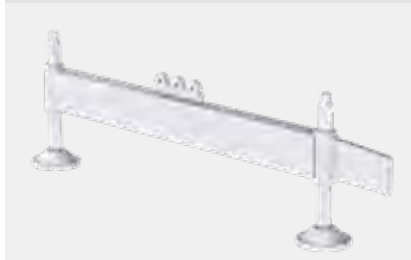

BALLAST FRAME TOWER M
234023



MOTOR BRACKET BASE TM04
234019 3.9 kg



HINGE PART
202041 1.75 kg

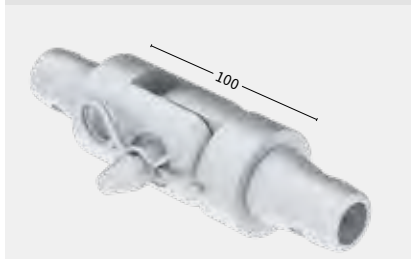

STABILISER M/L
234005 2.11 kg





V-Tower Model M

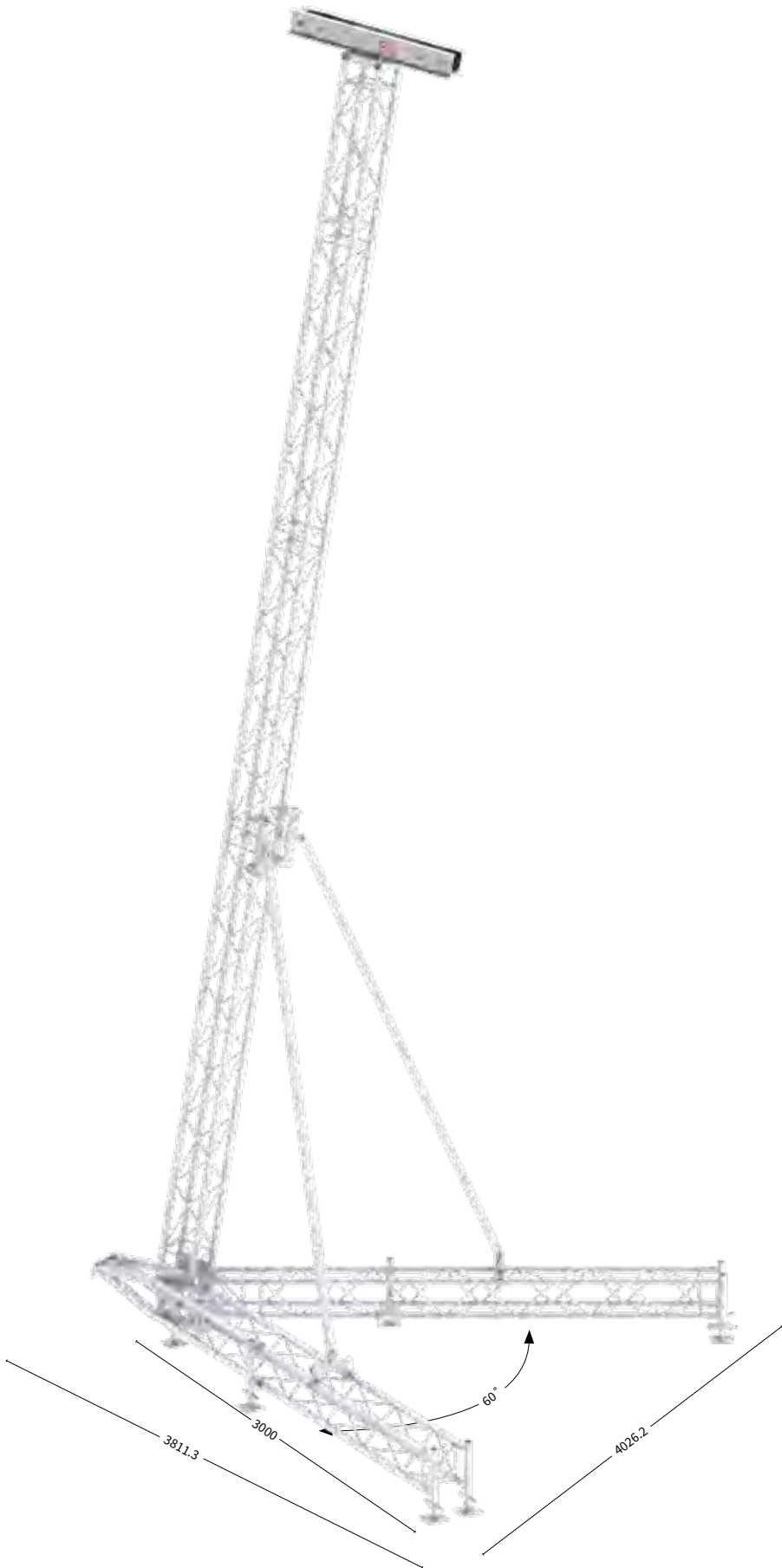

WHY V TOWER MODEL M?

- Self-Standing tower system to hang PA systems
- Minimal ballast required due to its shape
- Faster to build, compared to similar systems
- Complies with latest EN13814 standard for temporary structures
- Small footprint
- Use of standard M29S trusses
- Lifting help available

Technical specifications

- Max load 800 kg H = 750 cm
- Front surface 250 cm²
- Side surface 125 cm²
- Stabilizing profile 50 x 50 x 4 x 4 reinforced
- Max windspeed in service 20 m/s

VT CORNER TPM29S

631502

22.5 kg



VT HEAD SECTION M29S

631003

16.5 kg





Parts

631002	1	VT corner M29S
631003	2	Head section VTM09
631006	3	VT Stabiliser M29S
631008	4	VT Stabiliser adapter
202020	5	Hinge pin M
817008	6	Bolt M12x025 low head
202008	7	Half connector M52S
202018	8	Hinge female
251002	9	Scaff spindle adapter M29 clamp
251010	10	Scaff spindle adapter M29 receiver
203005	11	R-spring L05
631005	12	VT Stabiliser bracket M29S
251013	13	Scaff spindle 40 cm
128010	14	M29S-L300
128008	15	M29S-L200
128006	16	M29S-L100
631007	17	VT Erecting help

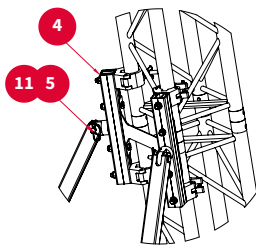
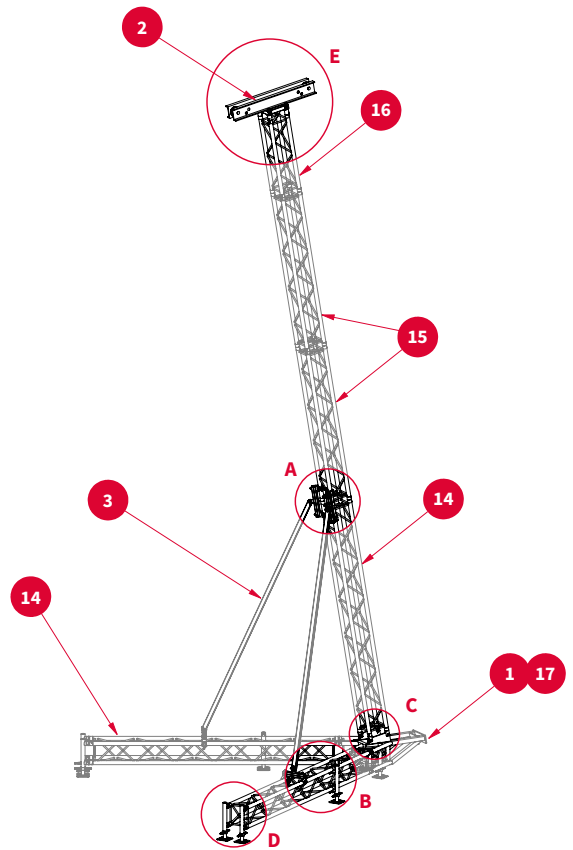

DETAIL A

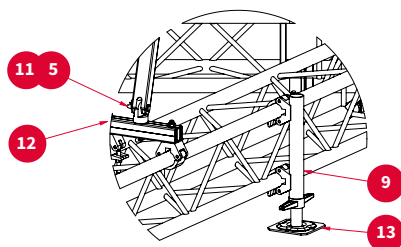

DETAIL B

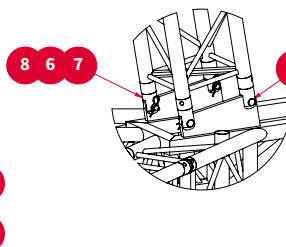

DETAIL C

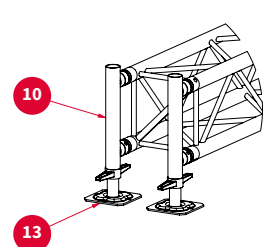

DETAIL D

VT STABILISER ADAPTER
631008 6.8 kg

VT STABILISER BRACKET M29S
631005 2.5 kg

VT STABILISER M29S
631006 9 kg

VT ERECTING HELP M
631007 14.5 kg

SCAFF SPINDLE ADAPTER CLAMP
251002

SCAFF SPINDLE ADAPTER RECEIVER
251010



Tower Model L

WHY TOWER MODEL L?

- Light weight sleeve block with minimised welding for optimal strength
- Modular concept allowing multiple configurations
- Tower truss with integrated ladder and diagonal bracing on all sides for optimum strength
- Slim design, less bulky footprint
- Sleeve blocks available for all kind of horizontal truss spans

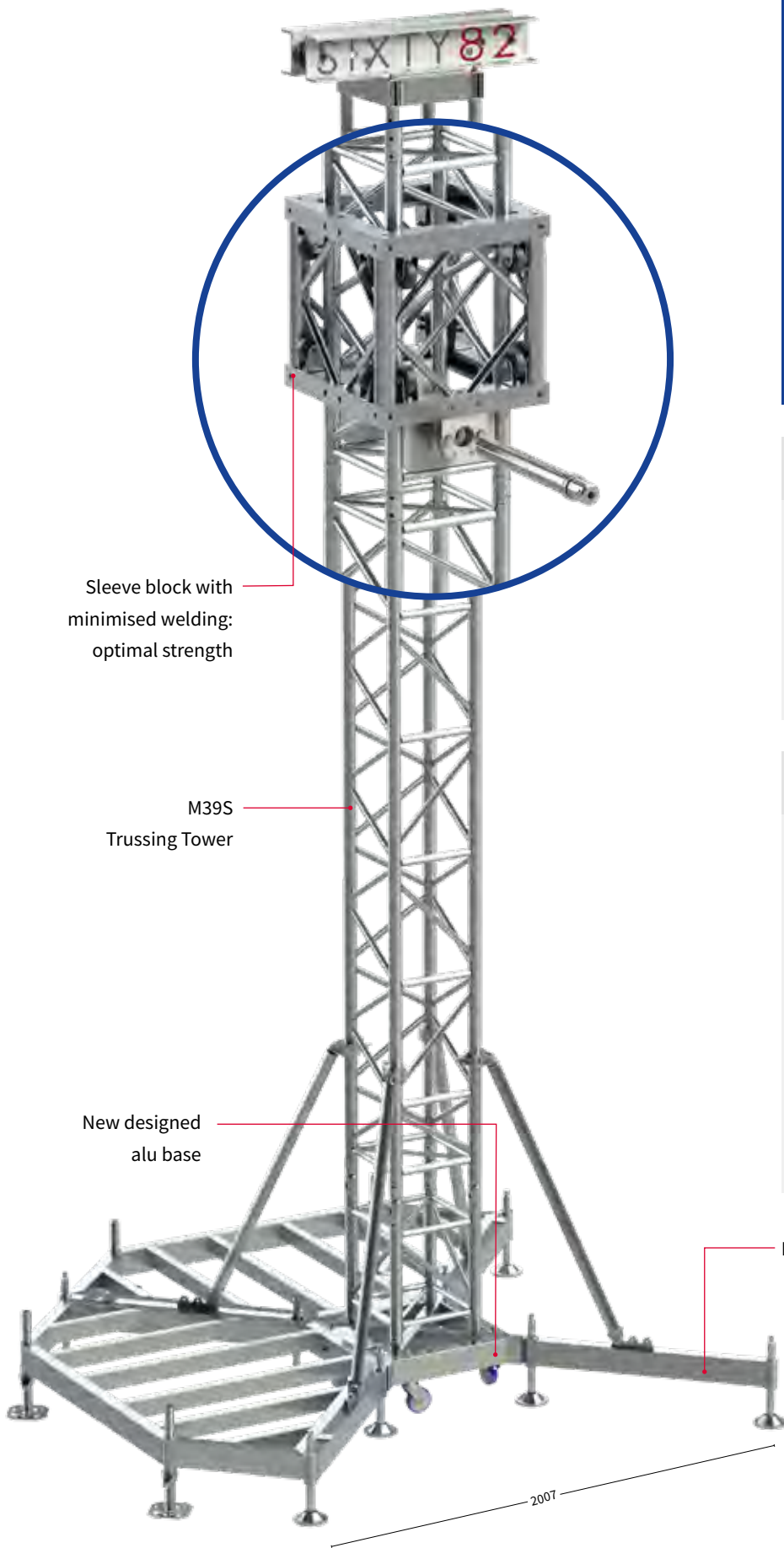

SLEEVE BLOCK L52S
232004

TL10
40 kg



SLEEVE BLOCK XL101R-F
232005

TL10
57.5 kg



HEAD SECTION **TL09**
233002 27 kg



MOTOR BRACKET **TL10**
234006 12 kg



M16x120
(818011 + 818009)

SAFE SYSTEM M39S **TL10**
192011 16 kg

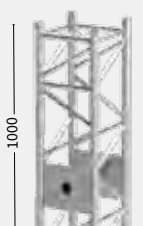

SAFE PIN M39S **TL10**
232019 3.89 kg



HORSE SHOE **TL10**
232012 0.3 kg



Bolts into sleeveblock

M39TOW

Code	Length
192001	50 cm
192002	100 cm
192003	150 cm
192004	200 cm
192005	250 cm
192006	300 cm
192007	350 cm
192008	400 cm

ALU BASE **TL04**
231004 17 kg

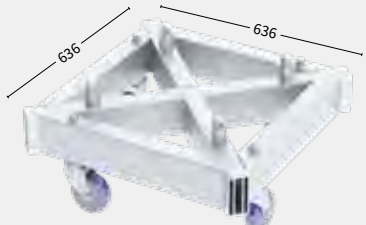

STABILISER M/L
234005 2.11 kg

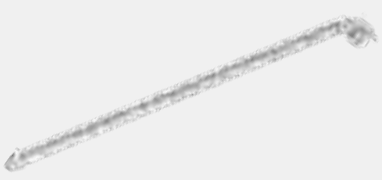

Locking pin (202025)



SHORT OUTRIGGER **TL11**
231005 4.32 kg



LONG OUTRIGGER **TL12**
231006

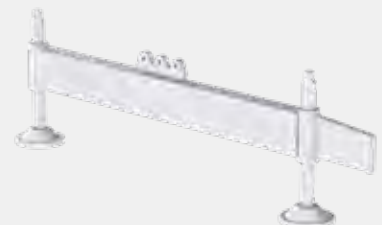

BALLAST FRAME TOWER L
234022



Scaff spindle 40cm (251013)

HINGE PART
202041 1.75 kg

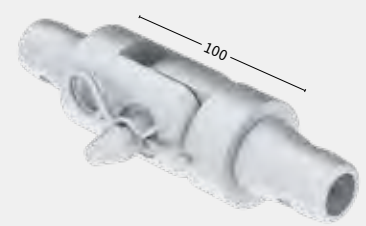

ERECTING SYSTEM L
234007 55.5 kg





Tower Model XL

WHY TOWER MODEL XL?

Sleeve block:

- Made of ultra high strength steel
- Integrated dead hang point
- Integrated guy wire attachments
- Interchangeable with conventional system as same OD

Tower mast sections:

- Integrated dead hang point (optional)
- Exchangeable with conventional systems

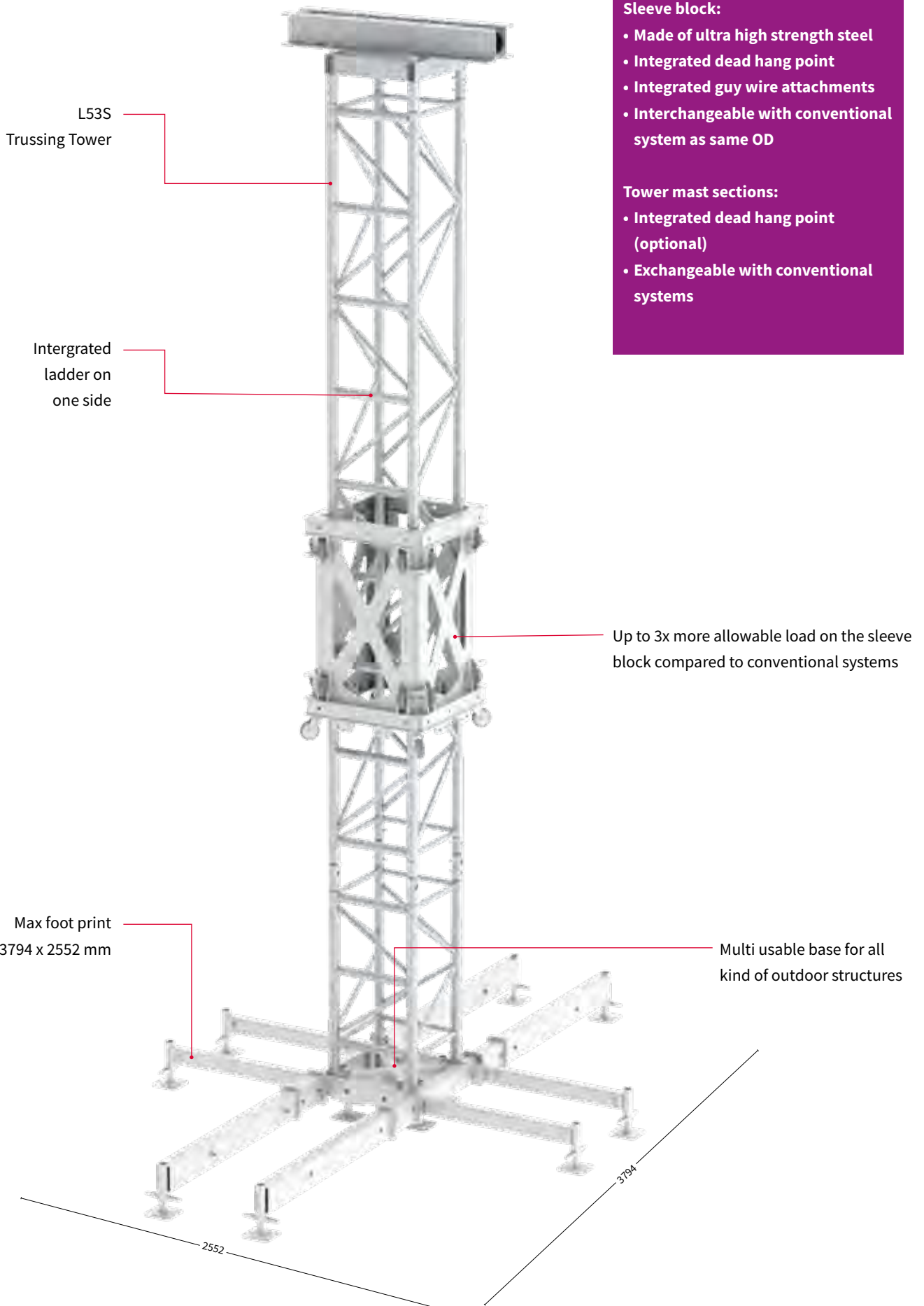

SLEEVE BLOCK XL101R-F
232008

TXL10
230 kg

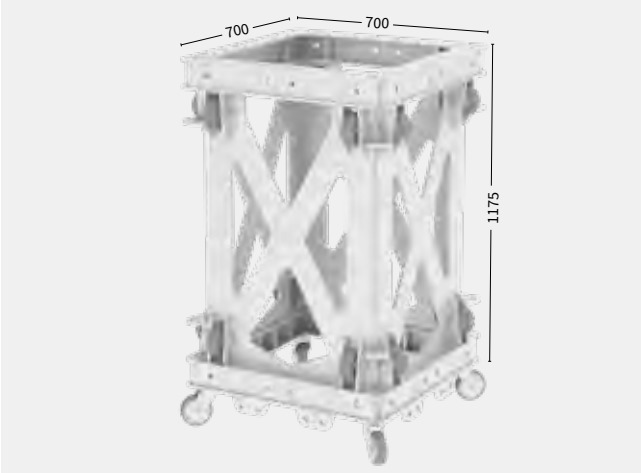

SLEEVE BLOCK XL101F-R/L52S
232009

TXL10

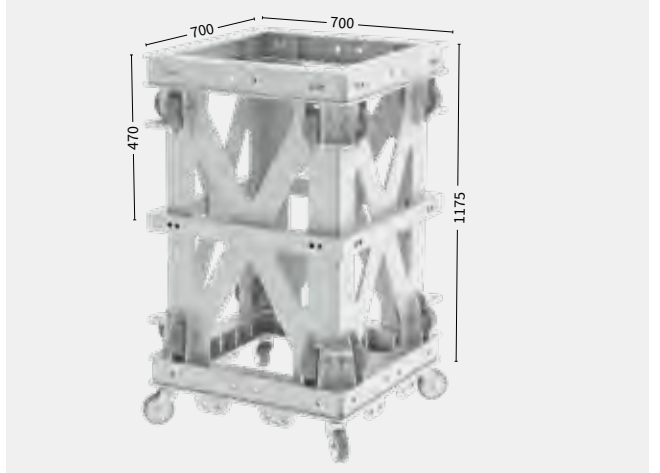

HEAD SECTION
233003

TXL09

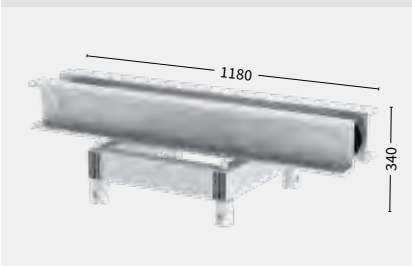

HORSE SHOE
232016

TXL10

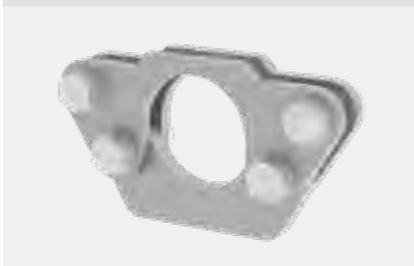

SAFE PIN XL53S
232017

TXL10



XL53TOW

Code	Length
193001	50 cm
193002	100 cm
193003	200 cm
193004	300 cm
193005	400 cm

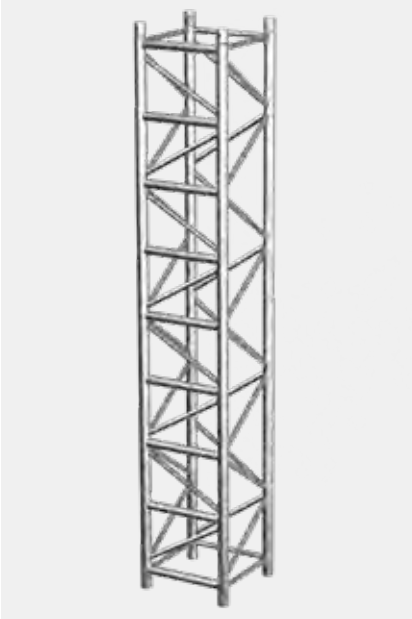

SAFE SYSTEM XL53S
193007

TXL10

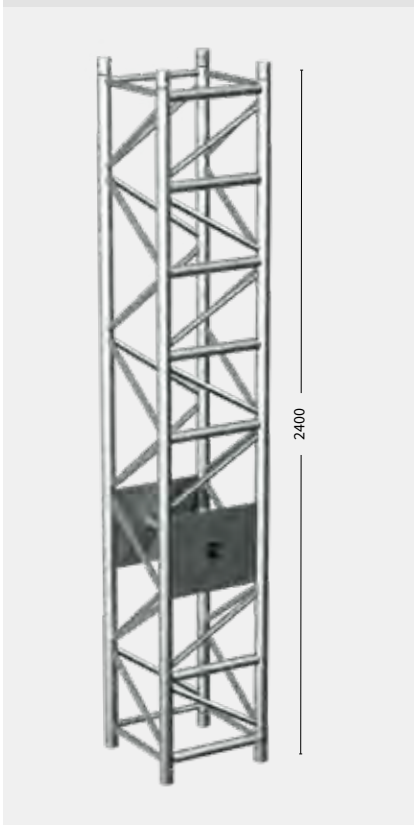

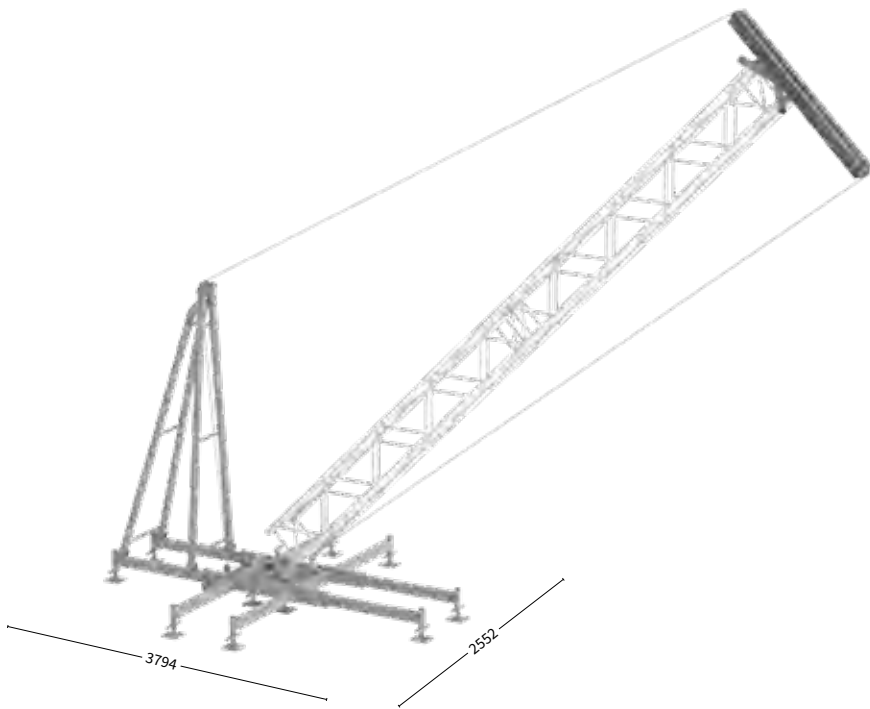

WHY MULTIBASE TOWER?

- Multi usable base for all kind of outdoor structures
- Self erecting by means of chain hoist
- Adapts to many different truss types
- Calculated and proven concept
- Can be used in conjunction with roof systems
- One size fits all head section
- Optional truss head
- Head section comes with multiple suspension points
- Calculated for coastal area (WS4) in Germany

MT BASE UNIT

231010

67 kg



MT OUTRIGGER M

231012

10 kg



MT OUTRIGGER L

231013

22.5 kg



MT ERECTING SYSTEM

234012

49 kg



MT HOIST BRACKET

234013

5.1 kg

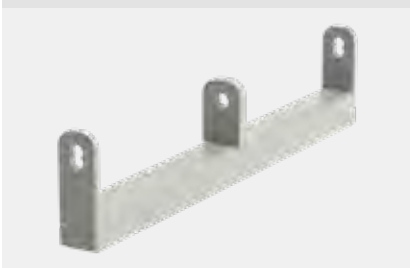

MT HEAD SECTION

233005

46 kg



MT CROSS

233006

C52

11 kg



SCAFF SPINDLE 20 CM

251012

2.16 kg



L-PIN 16-135

811008

0.25 kg



PA Tower	truss type	tower truss	Max. Pay Load	Front dimensions	Side dimensions	Ballast front	Ballast back	Ballast side	Ballast total	Ballast during erection
V1	L52S	10 m	1000 kg	6 m ²	3.4 m ²	-	1000 kg	2 x 1000 kg	3000 kg	2 x 500 kg (side)
V2	L52S	10 m	1000 kg	6 m ²	3.4 m ²	-	400 kg	2 x 1000 kg	2400 kg	2 x 500 kg (side)
V3	L52S	10 m	800 kg	5 m ²	3.4 m ²	-		2 x 1000 kg	2000 kg	2 x 500 kg (side)
V4	L52S	10 m	600 kg	4 m ²	3.4 m ²	-		2 x 900 kg*	1800 kg	2 x 500 kg (side)
V5	L52S	10 m	400 kg	3 m ²	2 m ²	-		2 x 400 kg*	1600 kg	2 x 500 kg (side)
V6	L35S	8 m	800 kg	3.5 m ²	2 m ²	300 kg**	400 kg	-	700 kg	400 kg (back)
V7	M39S / M39TOW	8 m	600 kg	3 m ²	2 m ²	200 kg**	400 kg	-	600 kg	400 kg (back)
V8	M29S	6 m	500 kg	3 m ²	2 m ²	200 kg**	200 kg	-	400 kg	400 kg (back)
Tech Tower										
V9	L35S / M39S / M39TOW	8 m	4 x 150 kg	4 x 1 m ²	4 x 1 m ²	-	-	2 x 600 kg	1200 kg	
V10	M29S	6.5 m	4 x 150 kg	4 x 1 m ²	4 x 1 m ²	-	-	2 x 400 kg	800 kg	
LED Portal										
								Every base		
V11	L52S	8 m incl. corner	LED 2000 kg PA 2 x 600 kg	LED 28 m ² PA 2 x 4 m ²	-	1000 kg	1000 kg	2 x 600 kg**	3200 kg	600 kg (back) or 2 x 500 kg side
V12	L35S	7 m incl. corner	LED 1000 kg PA 2 x 600 kg	LED 19.25 m ² PA 2 x 2.5 m ²	-	400 kg	400 kg	2 x 500 kg**	2200 kg	600 kg (back) or 2 x 500 kg side
V13	M39TOW / L52S	7 m incl. corner	LED 1000 kg PA 2 x 600 kg	LED 17 m ² PA 2 x 1.5 m ²	-	400 kg	400 kg	2 x 500 kg**	2200 kg	600 kg (back) or 2 x 500 kg side

* 50% of the payload may be subtracted proportionally from the ballast.

** The payload may be subtracted proportionally from the ballast.



Scan the QR-Code
to watch the Multibase Tower technical video

PA Tower

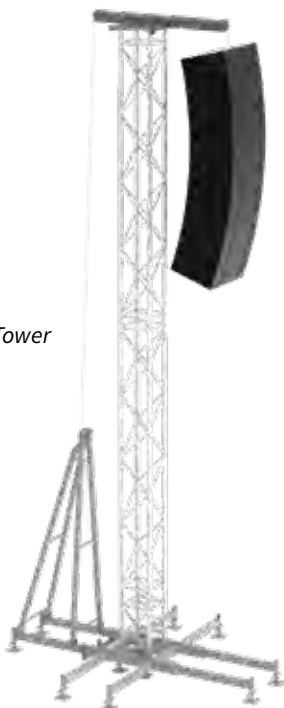

LED Portal

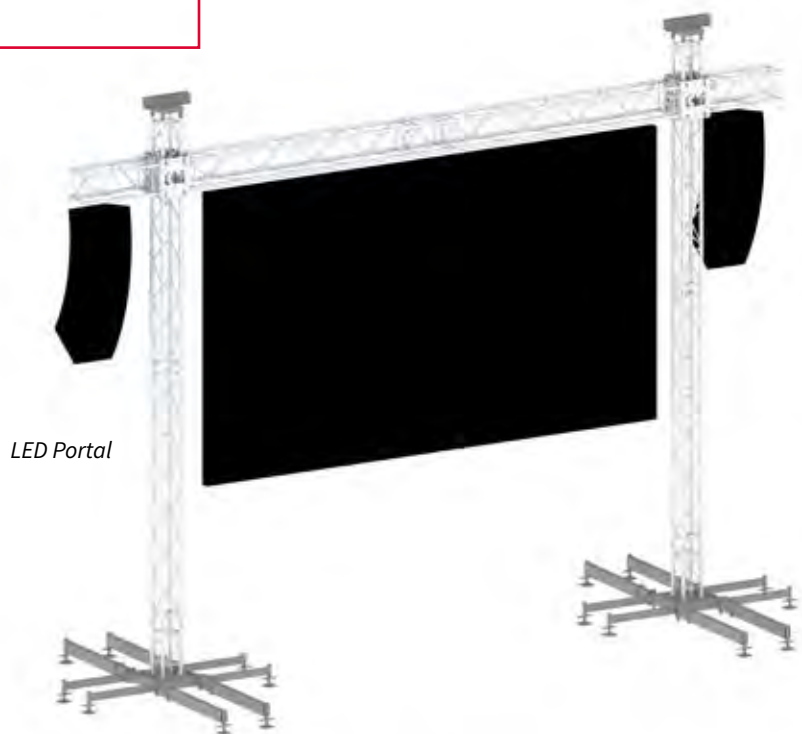



Arc Roof 6 x 4	78
Arc Roof 8 x 6	79
Arc Roof 10 x 8	80
Saddle roof 12 x 10	82
Saddle roof 10 x 8	86
Pitched Roof 14 x 12	88

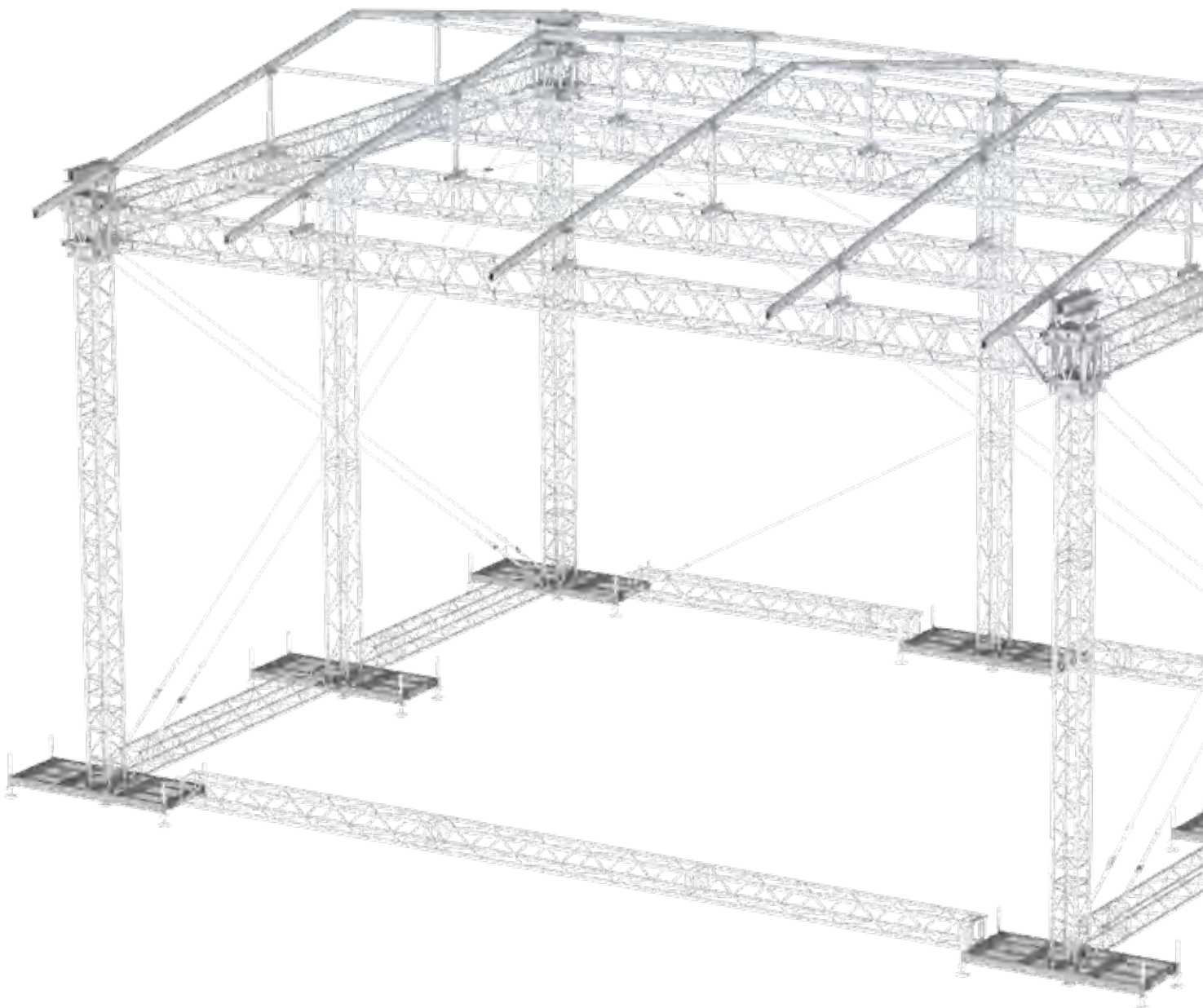

WHY ARC ROOF?

- Versatile temporary roof structure based on standard trusses
- No obstructing guy wires in sides
- Bespoke corners can be combined with Model M tower sleeve
- Competitively priced
- High loading compared to size
- Easy set-up by hand or material lifts
- Structurally calculated and proven concept
- Full aluminium structure
- Many options for staging or substructure
- Complies with European standards for temporary structures

	6 x 4 meter *	8 x 6 meter*	10 x 8 meter*
Loading capacity UDL	2100 kg	2441 kg	2502 kg
Loading capacity front cantilever	2 x 250 kg		
Self weight incl. wall canopies	610 kg	682 kg	1282 kg
Max peak gust wind speed in-service	20 m/s (measured at 10 m height)		
Max peak gust wind speed out-of-service	28 m/s		
Max peak gust wind during erecting	10 m/s		
Ballast	Depends on configuration		
Dimensions structure	See drawings		
Dimensions inside for stage platform	6 x 4 m	8 x 6 m	10 x 8 m
Trusses	M29S / M29T		
Canopy	Standard: grey/ black Optional: transparent Optional: other colors		
Staging	Several options possible like aluminium scaffolding system Subframe B		
Structural calculations	EN 13814 / Euro codes		
Miscellaneous	<ul style="list-style-type: none"> • Canopies fitted in kedar profile • No guy wires in side walls • Optional side wings • Baubuch on request • Structural calculations per EN 13814 		

* All data is based on calculated set-up. Other options are possible but need to be investigated on a case-by-case basis.

WHY ARC ROOF?

Boxcorner Adapter

- Machined plated adapter.
- Zero tolerance fitting of curved parts
- Compatible for triangle and square trusses
- Mountable on standard M29S Box corner



Stabilizer Tubes

- One tube, two pins.
- Hole integrated in curved truss
- Increases building speed
- Machined part adapter.



Sleeveblock Adapter

- Interchangeable with box corner adapter.
- Zero tolerance fitting of curved parts
- Compatible for triangle and square trusses
- Mountable on standard plated sleeveblock.



Ratchet Straps

- Hole integrated in curved truss
- Increases building speed



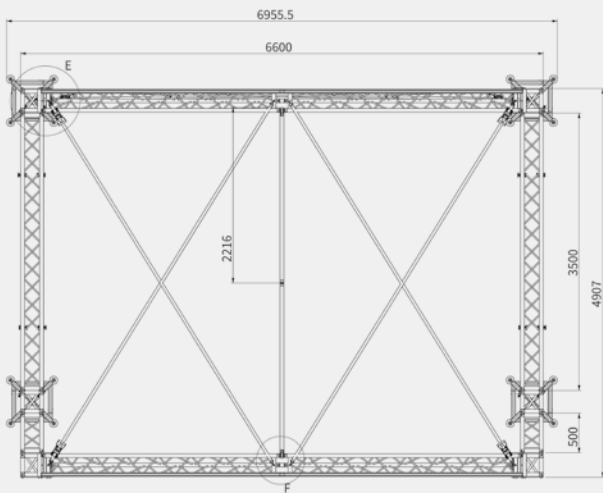
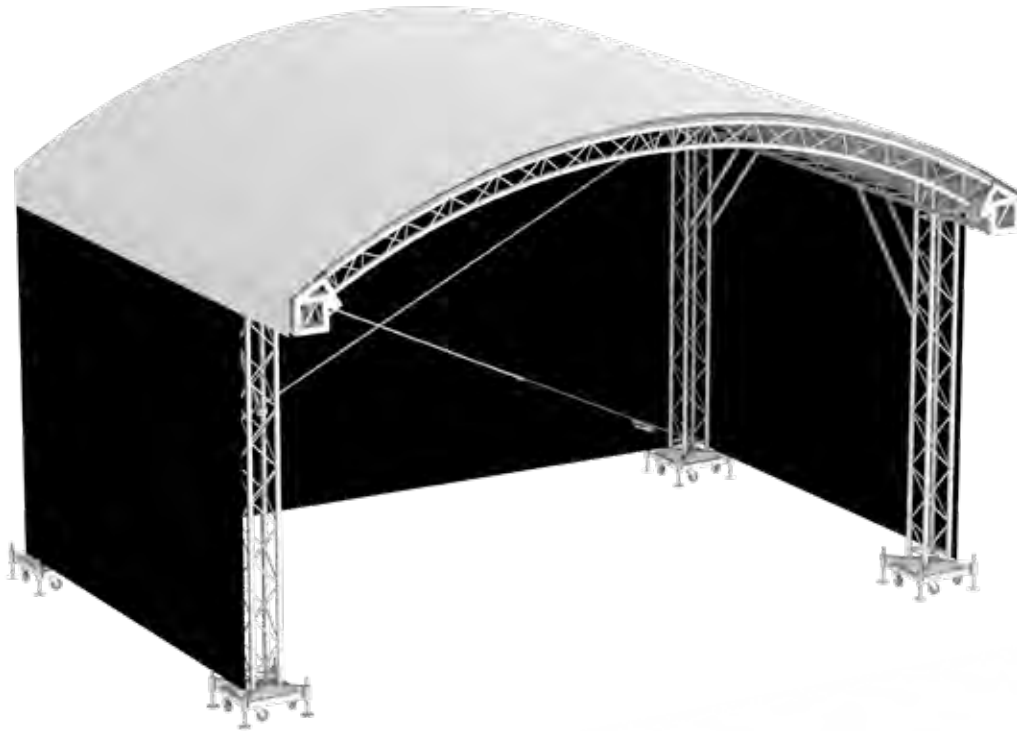

Top view

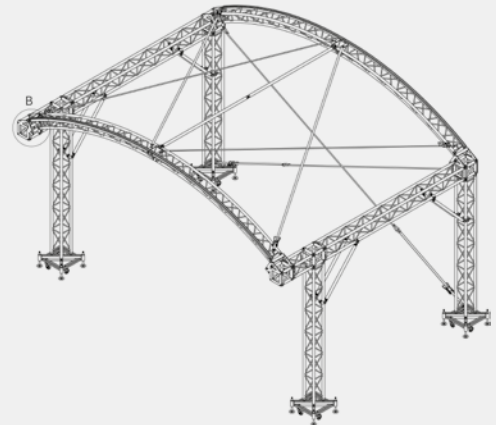

3D view

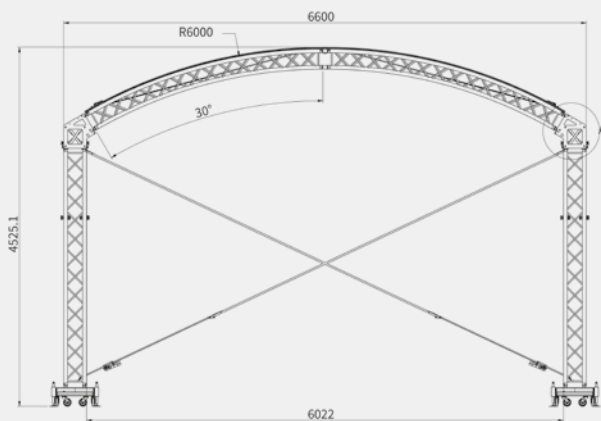

Front view

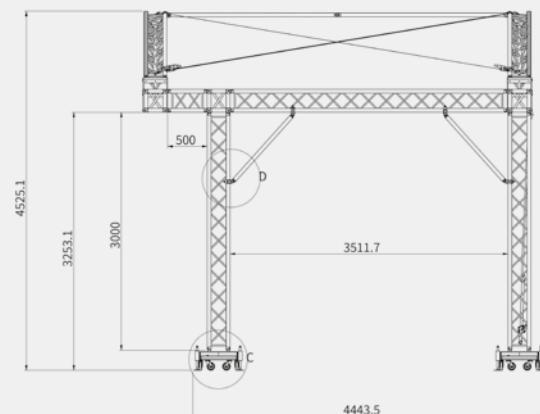

Left view

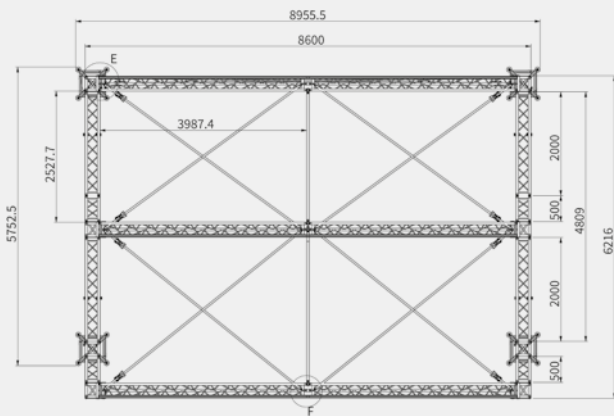
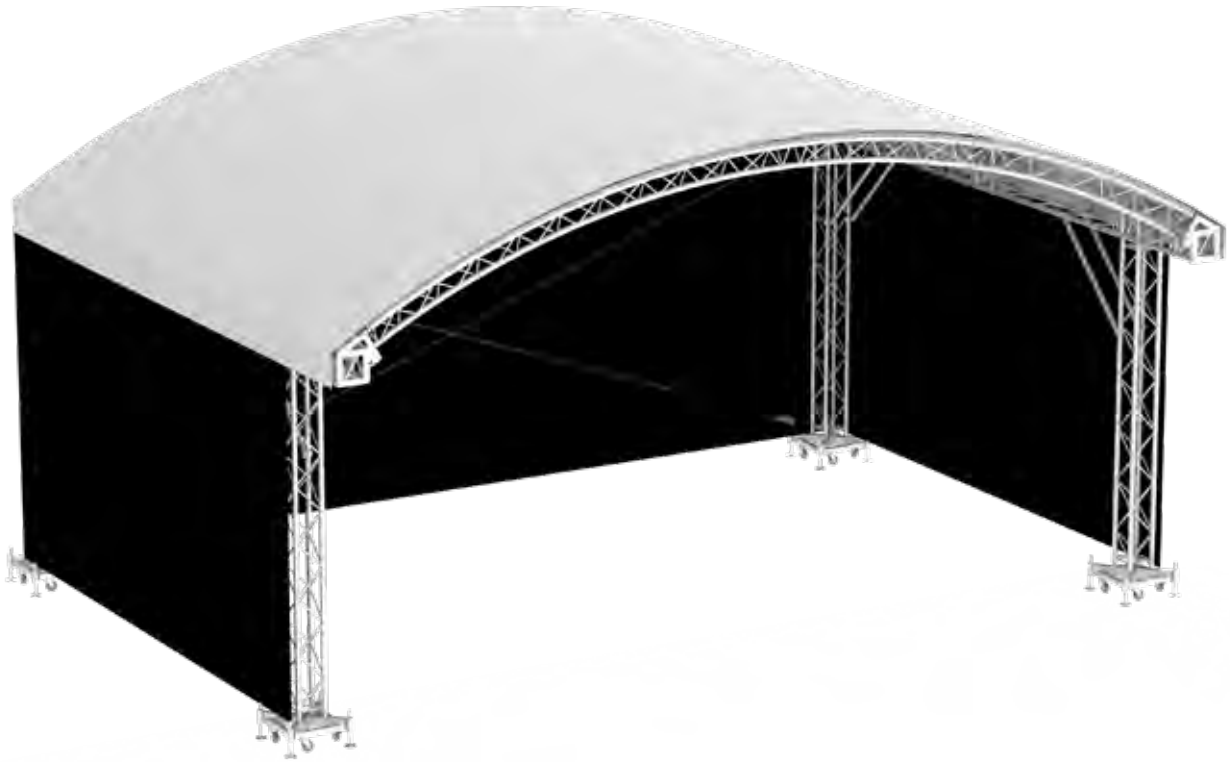

Top view

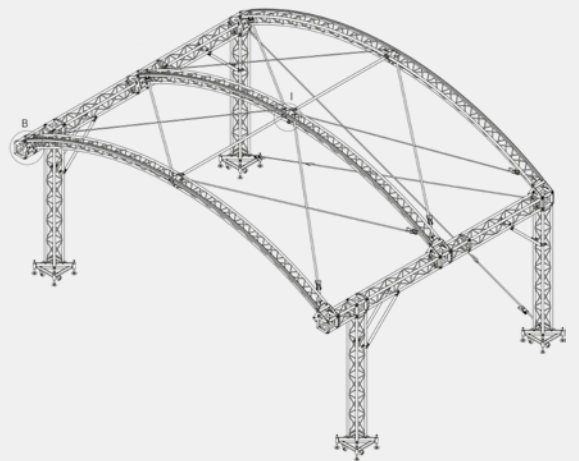

3D view

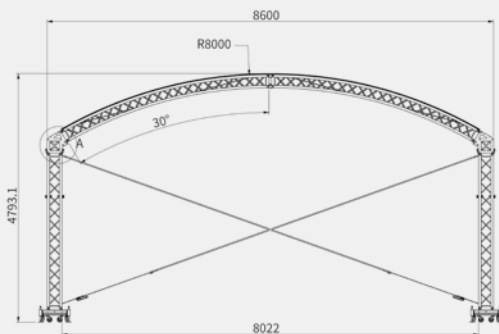

Front view

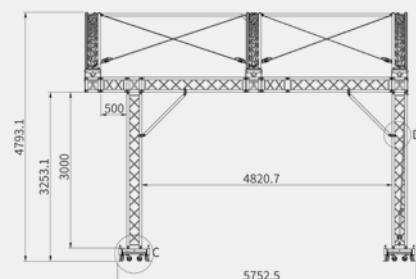

Left view

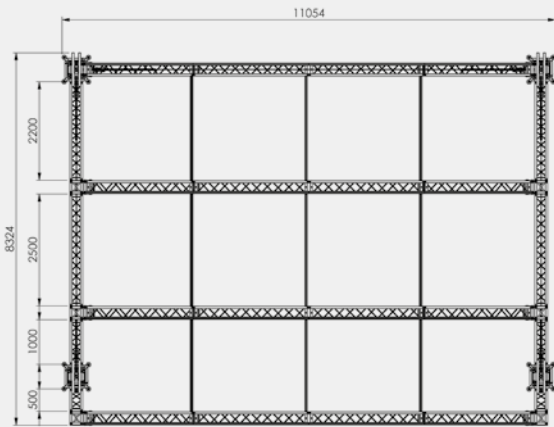
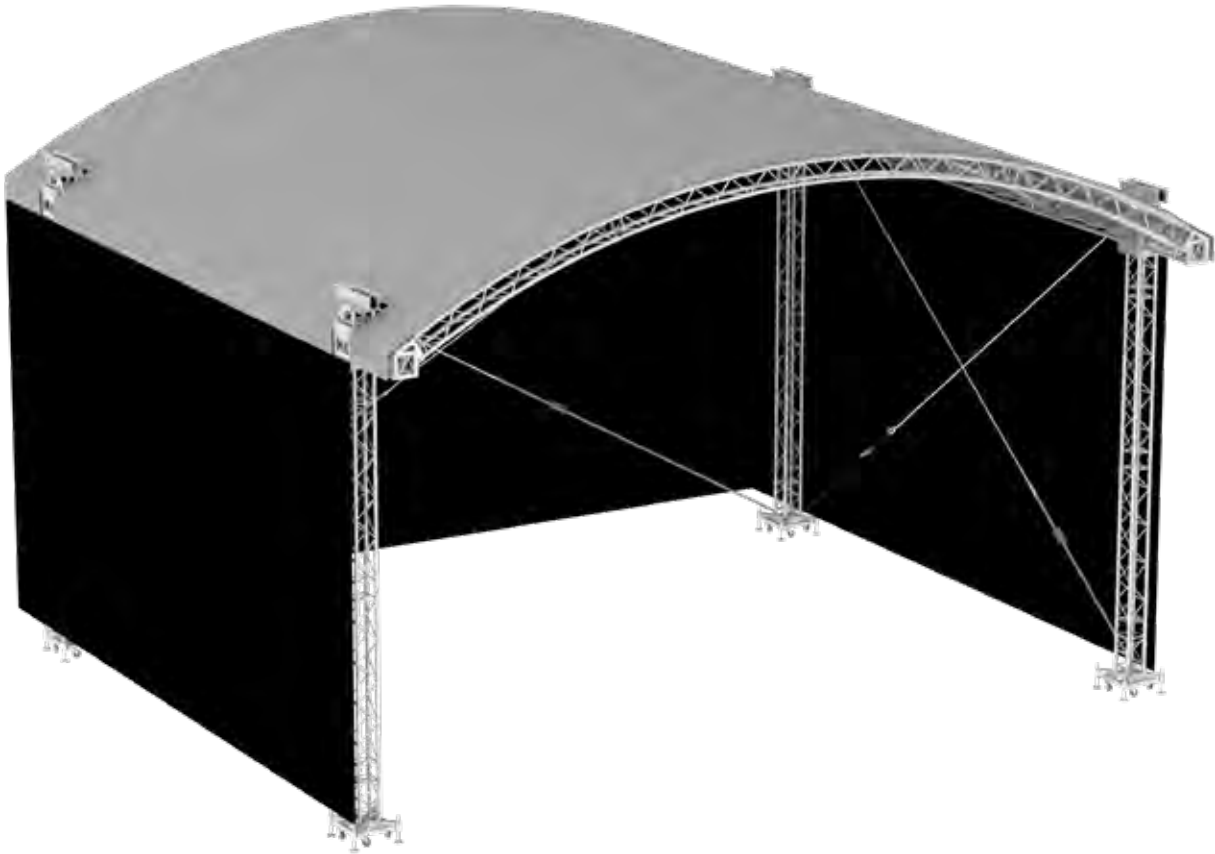

Top view

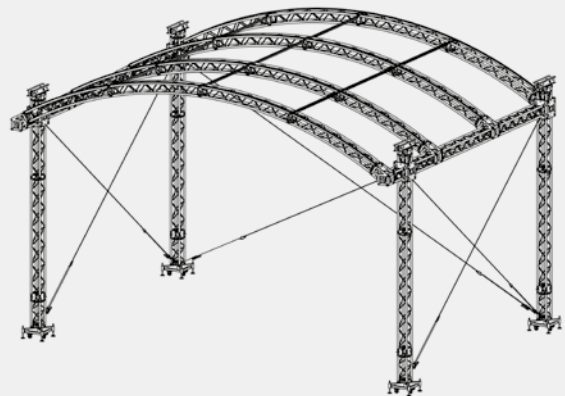

3D view

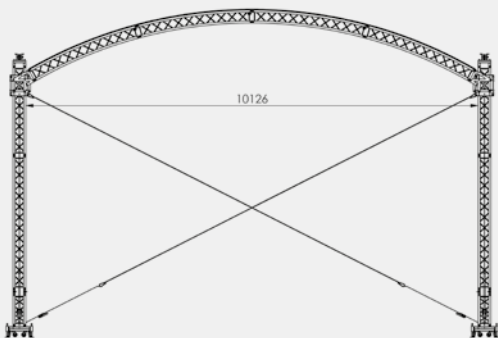

Front view

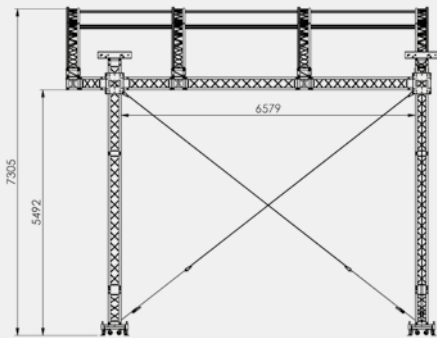

Left view





WHY SADDLE ROOF?

- Use of boxcorners instead of bespoke corners
- Gable rafter connection form-fit instead of clamps. This is much safer
- Gable rafter connection allows much faster set-up
- Pinned deadhang system to save time during set up
- Less lateral compression braces between rafters required due to use of M39S gable rafters

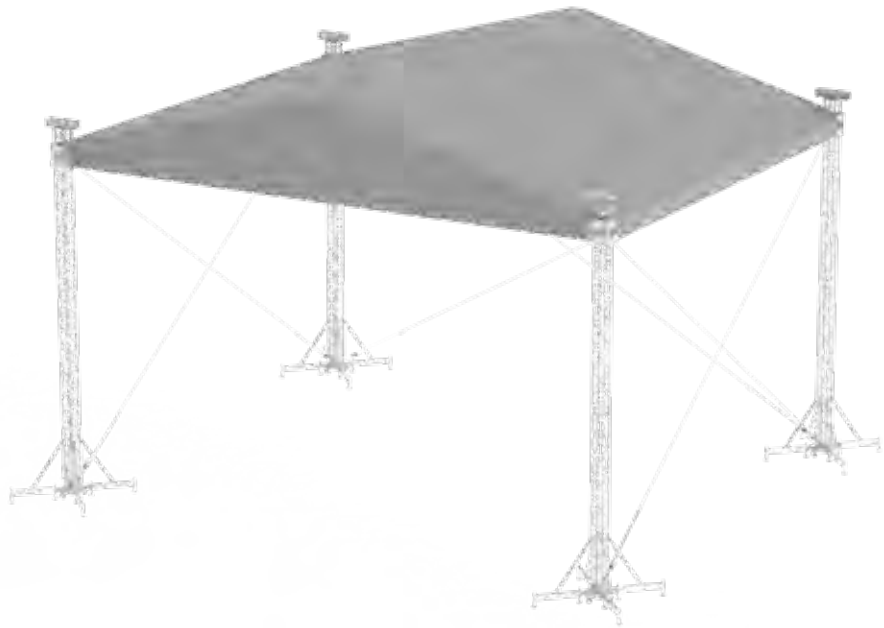

Loading capacity UDL	3982 kg
Loading capacity misc point loads	Depends on configuration
Loading capacity cantilever	1000 kg (4.5 m ²)
Self weight incl. wall canopies	2482 kg
Max peak gust wind speed in-service	20 m/s (measured at 10 m height)
Max peak gust wind speed out-of-service	28 m/s
Max peak gust wind during erecting	14 m/s
Ballast	Depends on configuration. Bespoke ballast bases / layher intergration available
Dimensions structure	W12.90 x D10.83 x H9.42*
Dimensions inside for stage platform	12x10 m
Trusses	M39S / M29S / M29T
Canopy	Standard: grey / black
	Optional: transparent / other colours
Staging	Several options possible like aluminium scaffolding system Subframe B
Structural calculations	DIN-EN 13814 / Euro codes
Miscellaneous	<ul style="list-style-type: none"> • Form fit connection between rafter and grid truss • Use of box corners. No bespoke corners • Auto-release system for wall canopies • Optional side wings • Ground ring or stage intergration for reducing ballast • Intermediate support towers for increased loading • Baubuch on request • M39S gable side rafters to minimise the use of compression braces • Decreased set up times due to pin fork connections instead of clamps

* All data is based on calculated set-up. Other options are possible but need to be investigated on a case-by-case basis.

WHY SADDLE ROOF?

Corners

- Machined connection strip
- Highly increased building speed
- One adapter, 6 pins
- Zero tolerance fitting
- No specific building order
- Compatible for every roof size



- Machined plated adapter
- Zero tolerance fitting
- Mountable on standard M39S Box corner
- Compatible for every roof size

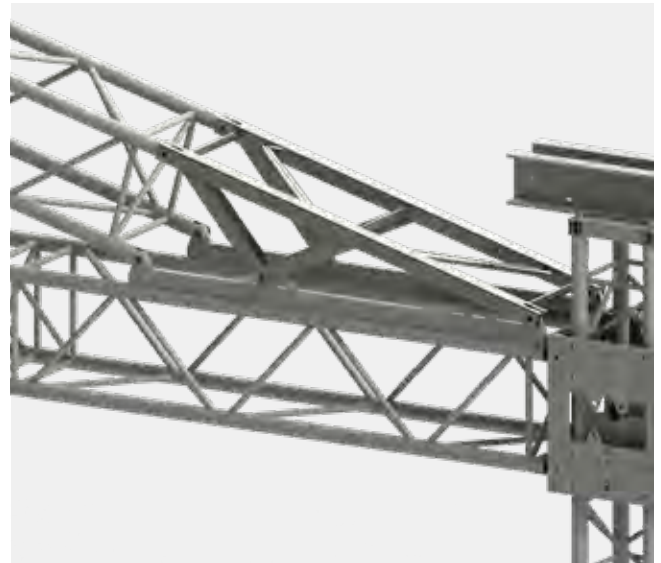

Safe System

- Increases building speed
- Strong and secure locking
- All towers exact same height



Stabilizers

- Machined plated adapter
- Zero tolerance fitting
- Mountable on standard M39S Box corner
- Compatible for every roof size



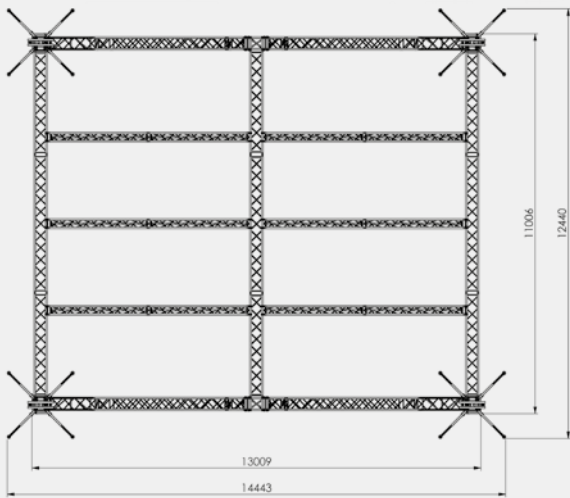
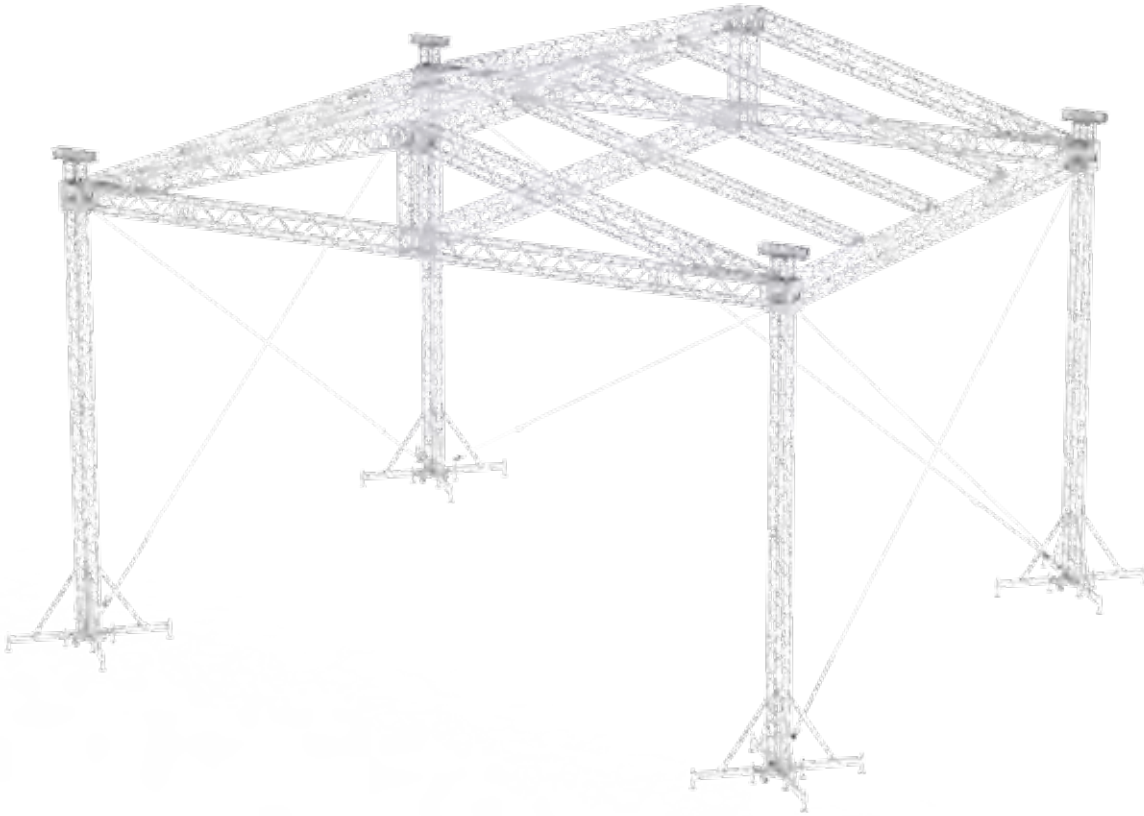

Top view

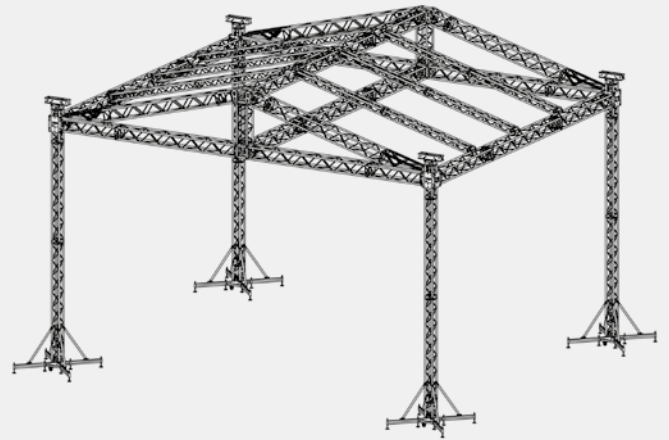

3D view

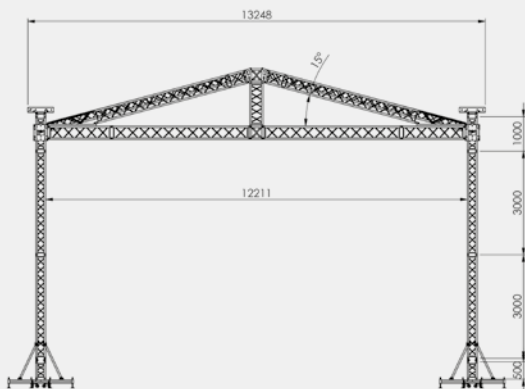

Front view

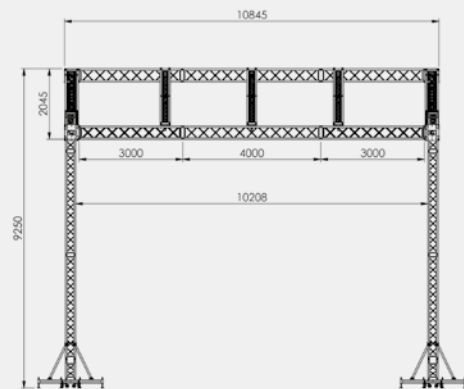

Left view





WHY SADDLE ROOF?

- Use of boxcorners instead of bespoke corners
- Gable rafter connection form-fit instead of clamps. This is much safer
- Gable rafter connection allows much faster set-up
- Pinned deadhang system to save time during set up
- Less lateral compression braces between rafters required due to use of M39S gable rafters

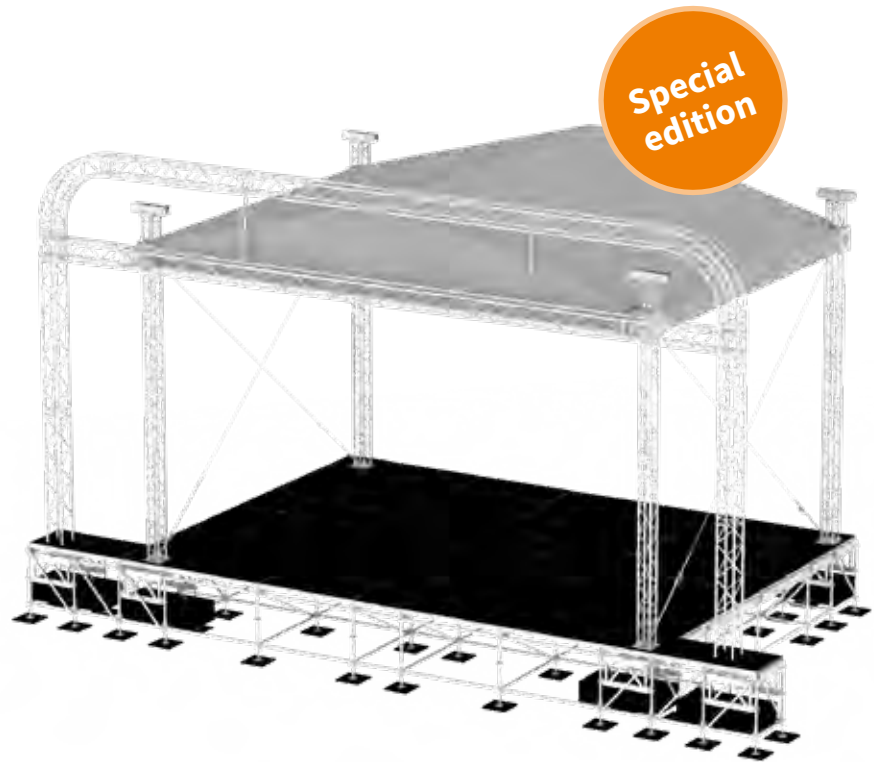

Loading capacity UDL	4482 kg
Loading capacity misc point loads	Depends on configuration
Loading capacity cantilever	1000 kg (4.5 m ²)
Self weight incl. wall canopies	2182 kg
Max peak gust wind speed in-service	20 m/s (measured at 10 m height)
Max peak gust wind speed out-of-service	28 m/s
Max peak gust wind during erecting	14 m/s
Ballast	Depends on configuration. Bespoke ballast bases / layher integration available
Dimensions structure	W10.90 x D7.83 x H9.10*
Dimensions inside for stage platform	10 x 7 m
Trusses	M39S / M29S / M29T
Canopy	Standard: grey / black Optional: transparent / other colours
Staging	Several options possible like aluminium scaffolding system StageFrame82
Structural calculations	DIN-EN 13814 / Euro codes
Miscellaneous	<ul style="list-style-type: none"> • Form fit connection between rafter and grid truss • Use of box corners. No bespoke corners • Auto-release system for wall canopies • Optional side wings • Ground ring or stage intergration for reducing ballast • Intermediate support towers for increased loading • Baubuch on request • M39S gable side rafters to minimise the use of compression braces • Decreased set up times due to pin fork connections instead of clamps

* All data is based on calculated set-up. Other options are possible but need to be investigated on a case-by-case basis.

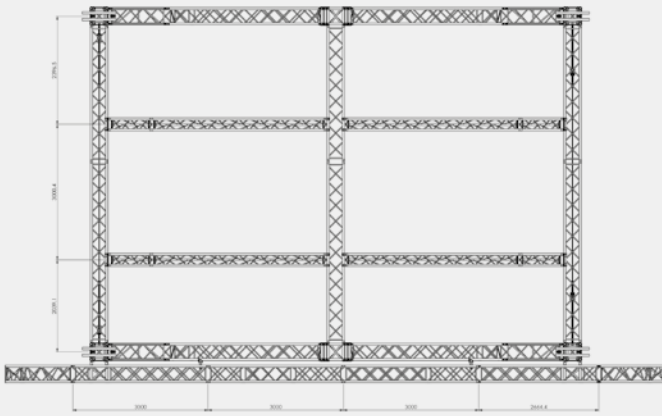
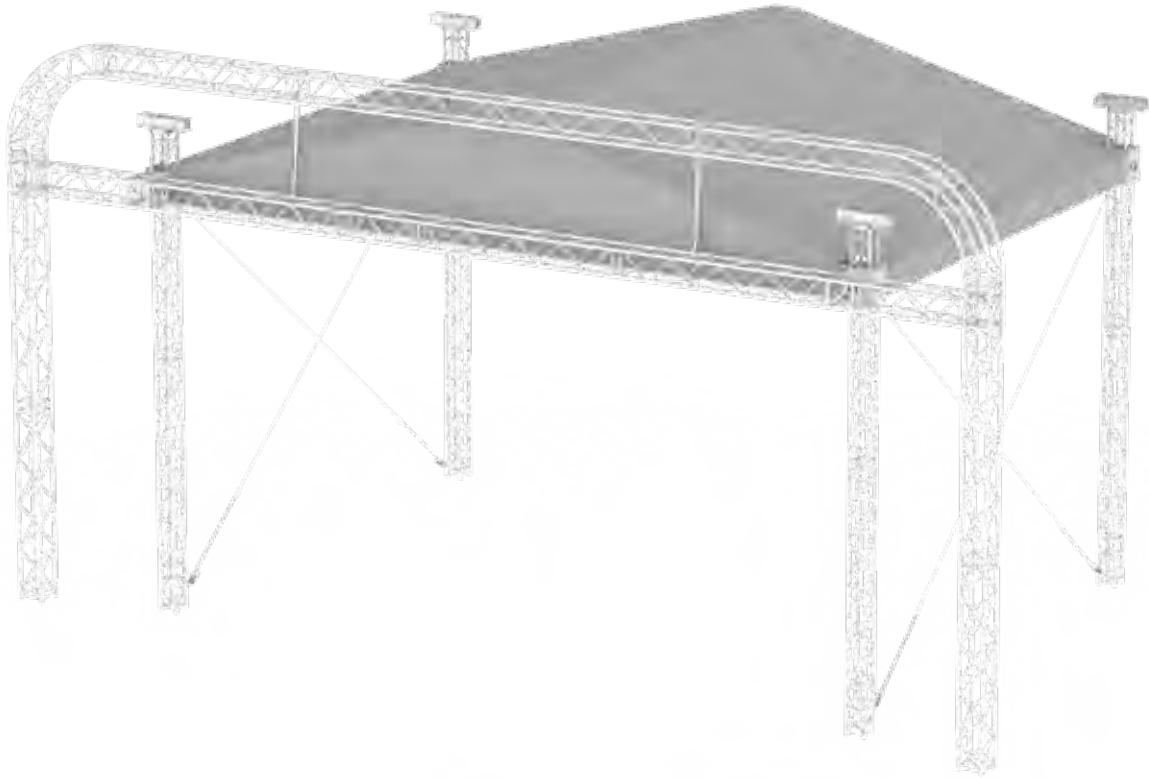

Top view

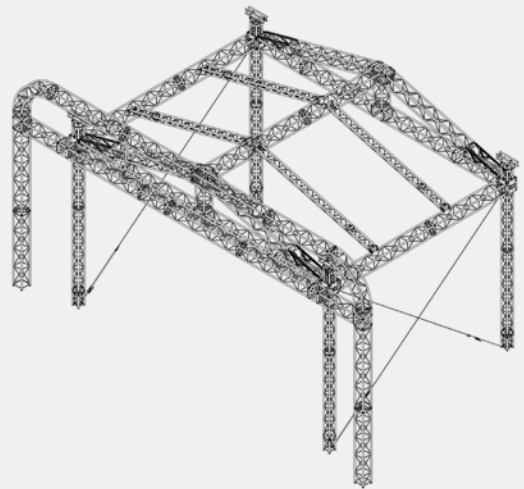

3D view

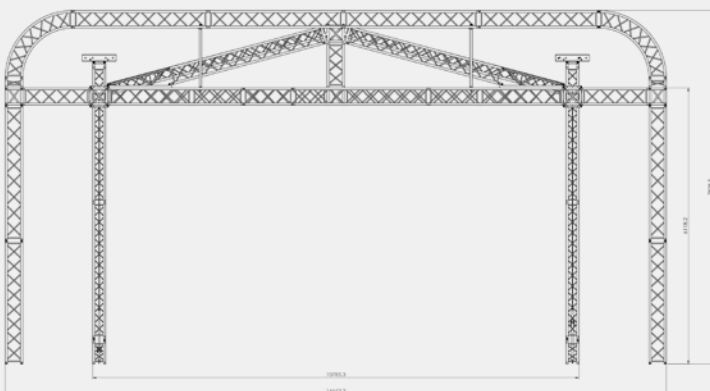

Front view

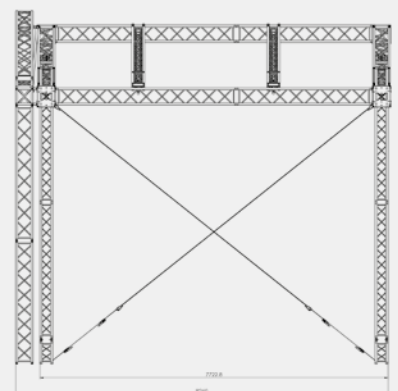

Left view



WHY PITCHED ROOF?

- Hurricane proof design (max 40 m/s)
- Canopies sit in kedar profiles for ease of build
- Auto-release system for wall canopies
- Ground ring for reduced ballast
- Bespoke tower bases for correct integration of ballast
- High load capacity
- Full aluminium structure
- Many options for staging or substructure
- Complies with European standards for temporary structures

Loading capacity UDL	5645 kg
Loading capacity misc point loads	7000 kg
Loading capacity front cantilever beams	2 x 500 kg
Self weight incl. wall canopies	3197 kg
Max peak gust wind speed in-service	20 m/s (measured at 10 m height)
Max peak gust wind speed out-of-service	28 m/s - 40 m/s
Max peak gust wind during erecting	14 m/s
Ballast	Depends on configuration Bespoke ballast bases
Dimensions structure	W15.08 x D13.96 x H9.93
Dimensions inside for stage platform	14 x 12 m
Trusses	M39S / M39TOW / L52S
Canopy	Standard: grey / black Optional: transparent
Staging	Several options possible like aluminium scaffolding system StageFrame82
Structural calculations	EN 13814 / Euro codes
Miscellaneous	<ul style="list-style-type: none"> • Canopies fitted in kedar profile • Auto-release system for wall canopies • Optional side wings • Ground ring for reducing ballast • Intermediate support towers for increased loading • Baubuch on request • Structural calculations per DIN-EN-13814

* All data is based on calculated set-up. Other options are possible but need to be investigated on a case-by-case basis.

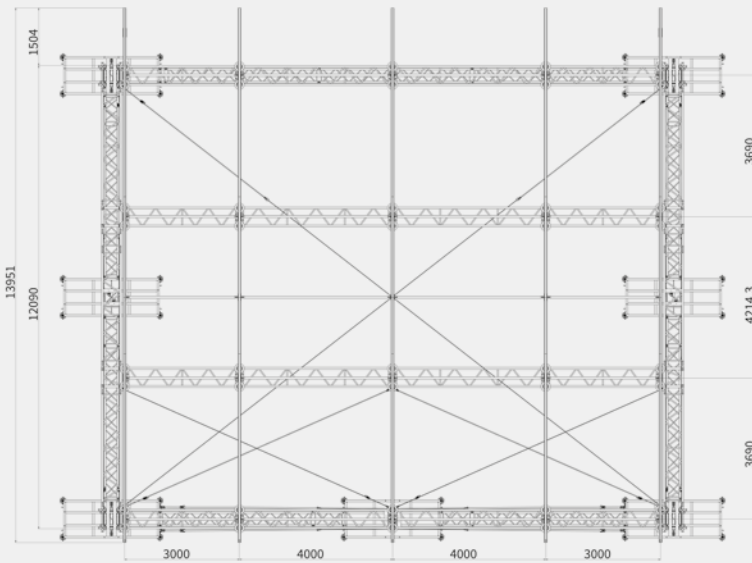

Top view

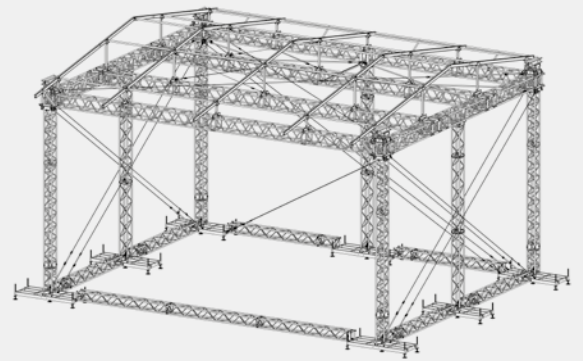

3D view

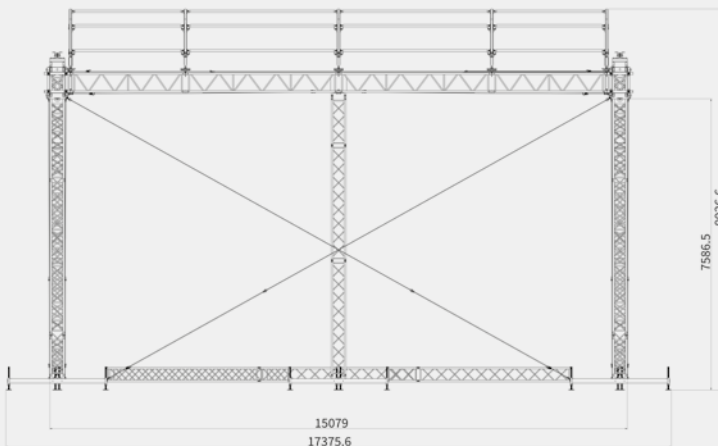

Front view

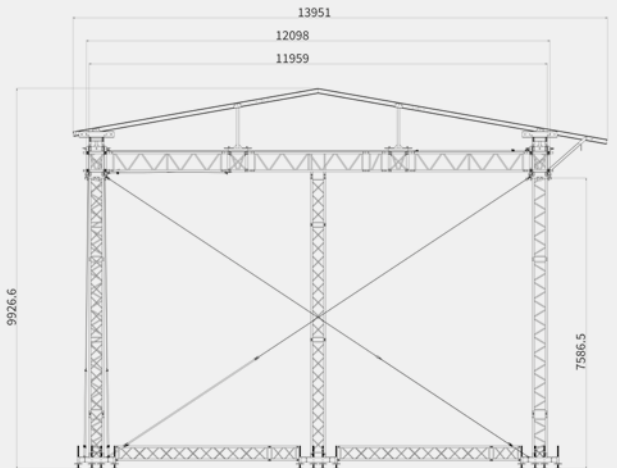

Right view



LED Screen Support 6 x 4	92
LED Screen Support 8 x 6	94





WHY LED SCREEN SUPPORT?

- Versatile LED Screen Support structure based on standard trusses
- Easy set-up due to fixed base structure
- Structurally calculated and proven concept
- Full aluminium structure
- Use of multibase for easy positioning of ballast
- Rafters can be lifted together with erection of tower to save assembly time
- Bespoke head section with integrated brace connection for fast set up and less bespoke parts
- Possibility to deadhang at ground level which eliminates the need to climb the towers



Scan the QR-Code
to watch the LED Screen
Support technical video

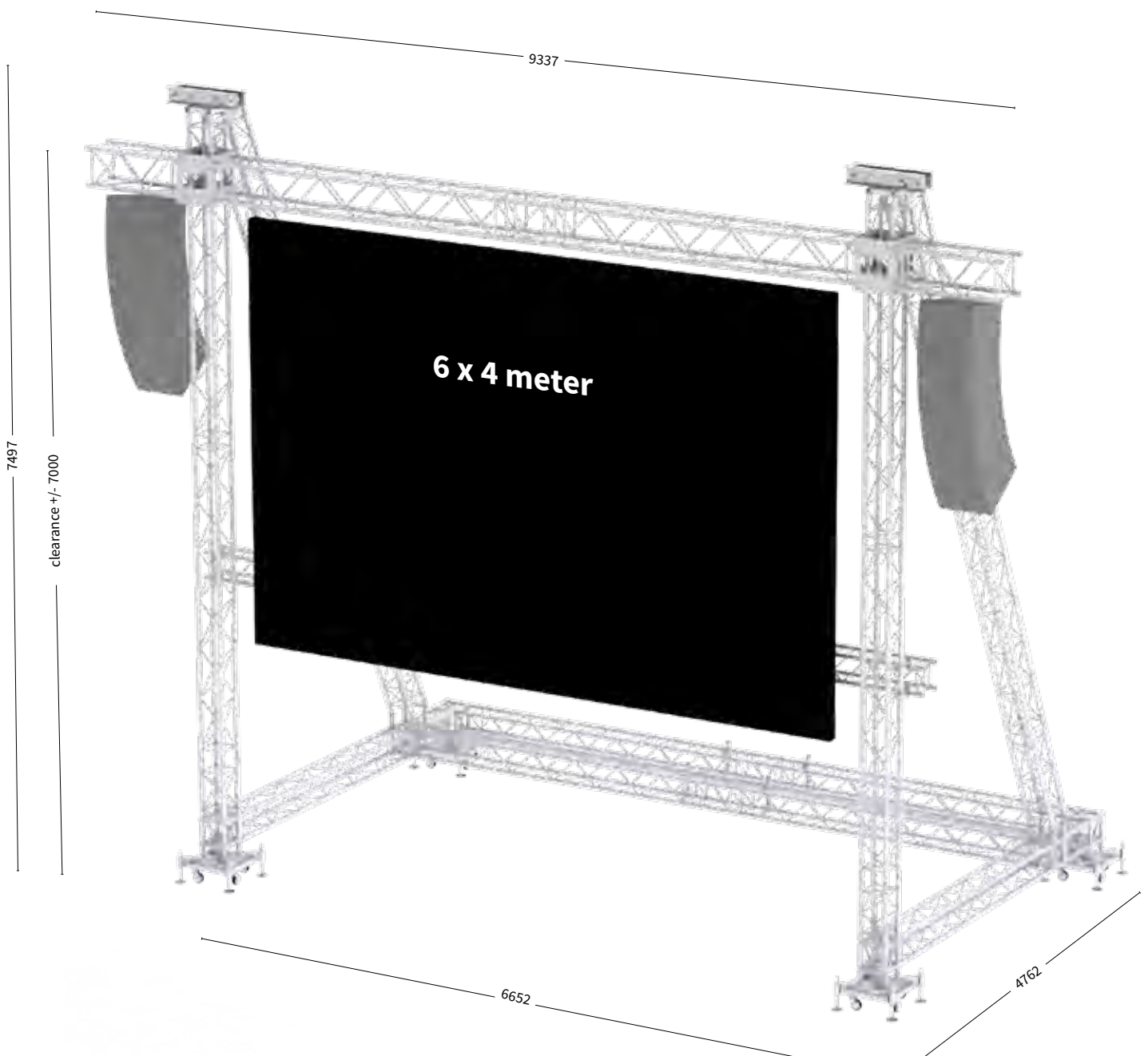



Max screen size	6 x 4 meter
Max PA size front	1.5 m ²
Max screen weight	1500 kg
Max PA weight	2 x 250 kg
Max peak gust wind speed in-service	20 m/s (measured at 10 m height)
Max peak gust wind speed out-of-service	27 m/s
Max peak gust during lifting	8 m/s
Ballast (if screen weight is 1500kg)	2 x 900 kg
Dimensions	See drawing
Trusses	M29S / M29T / M39S

- * Above data based on calculated set-up. Other options are possible but need to be investigated on a case-by-case basis.
- * Calculations per DIN-EN13814:2013 for WS 1-2 in-land in Germany.
- * Baubuch on request.

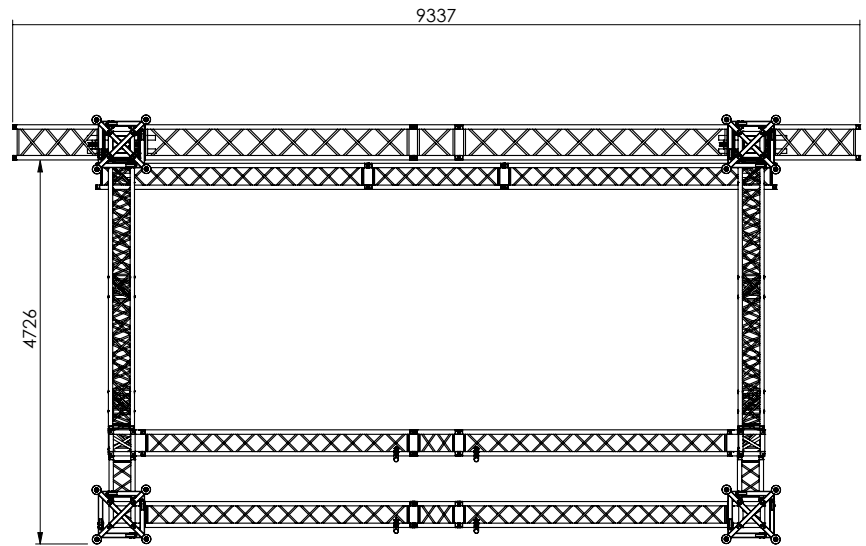

Top view

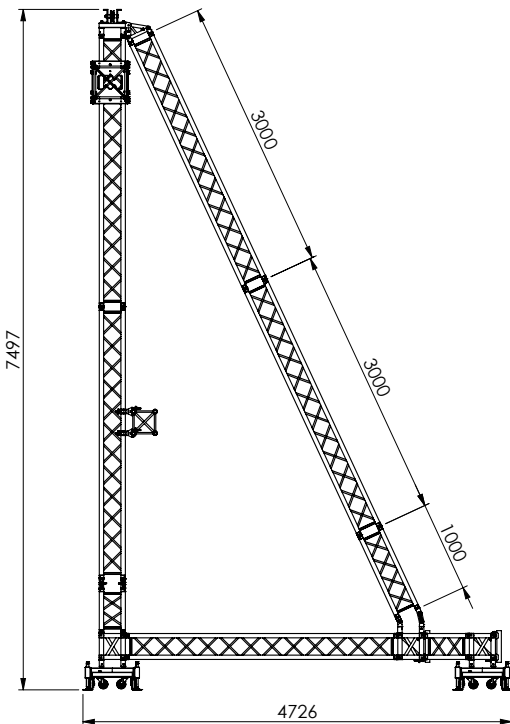

Left view

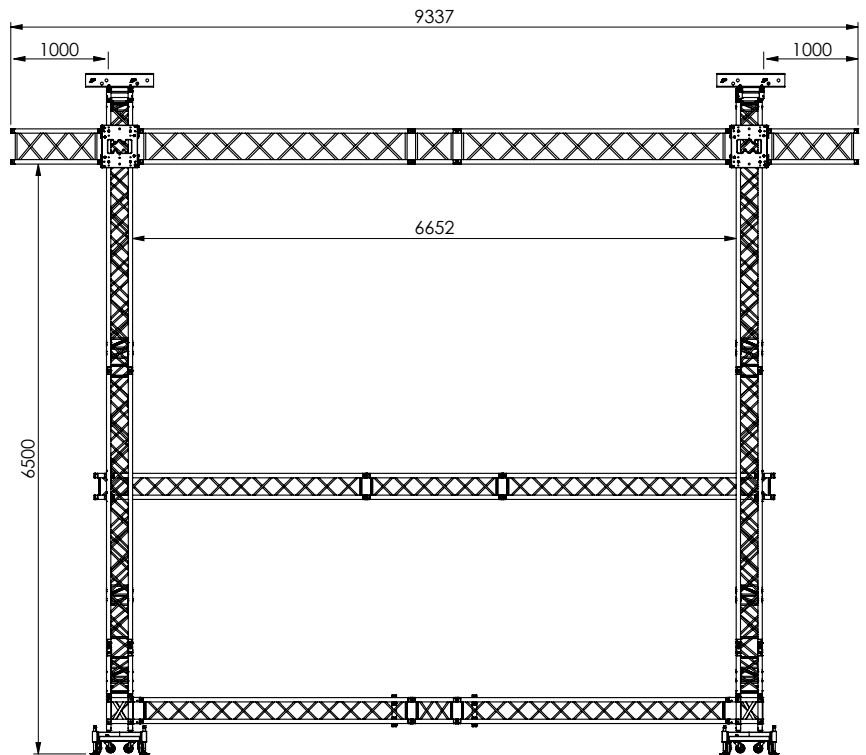

front view

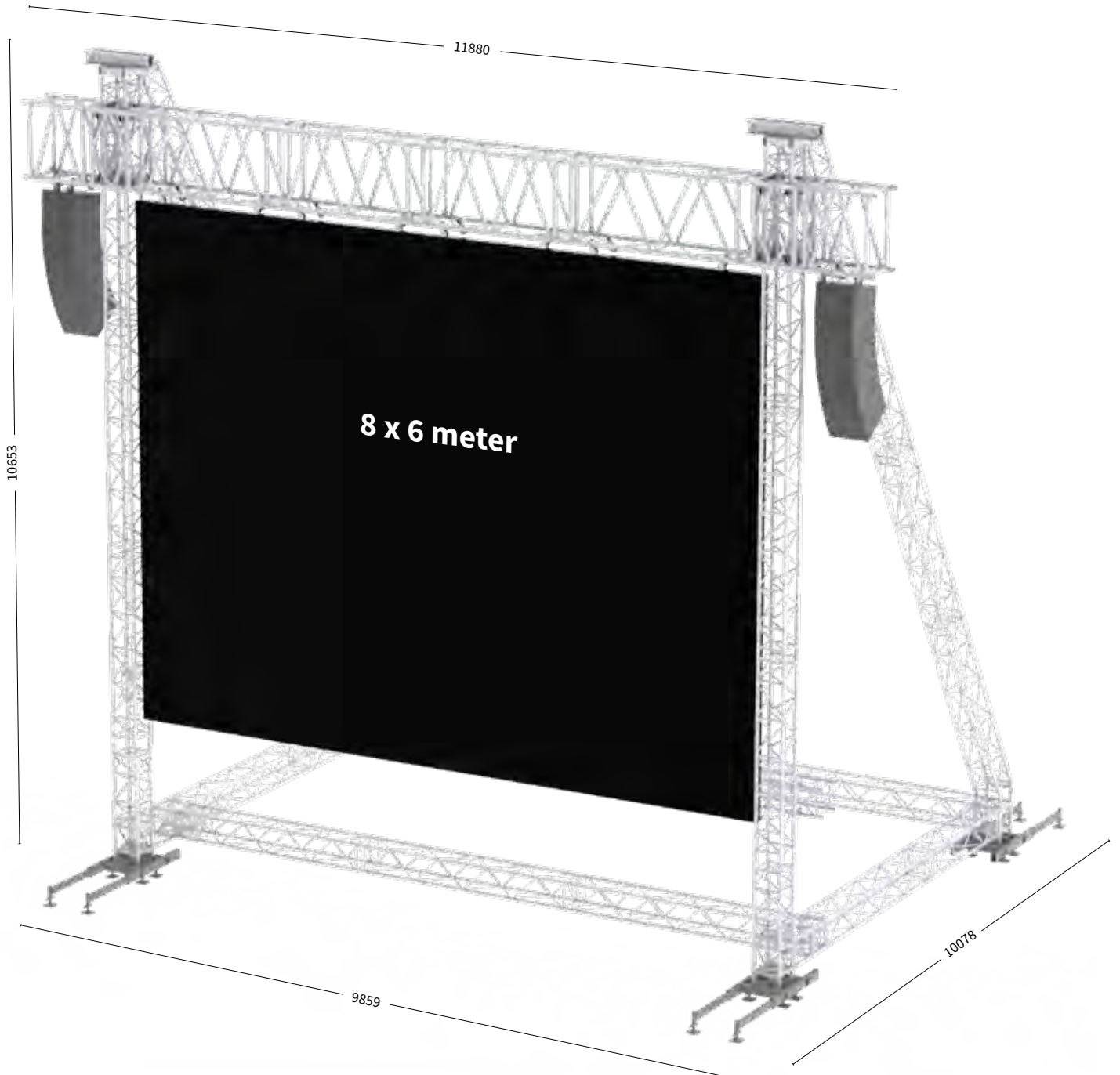



Max screen size	8 x 6 meter
Max PA size front	2.5 m ²
Max screen weight	3000 kg
Max PA weight	2 x 500 kg
Max peak gust wind speed in-service	20 m/s (measured at 10 m height)
Max peak gust wind speed out-of-service	27 m/s
Max peak gust during lifting	8 m/s
Ballast (if screen weight is 1500kg)	2 x 1000 kg and 2 x 300 kg
Dimensions	See drawing
Trusses	M39TOW / M39S / XL101

- * Above data based on calculated set-up. Other options are possible but need to be investigated on a case-by-case basis.
- * Calculations per DIN-EN13814:2013 for WS 1-2 in-land in Germany.
- * Baubuch on request.

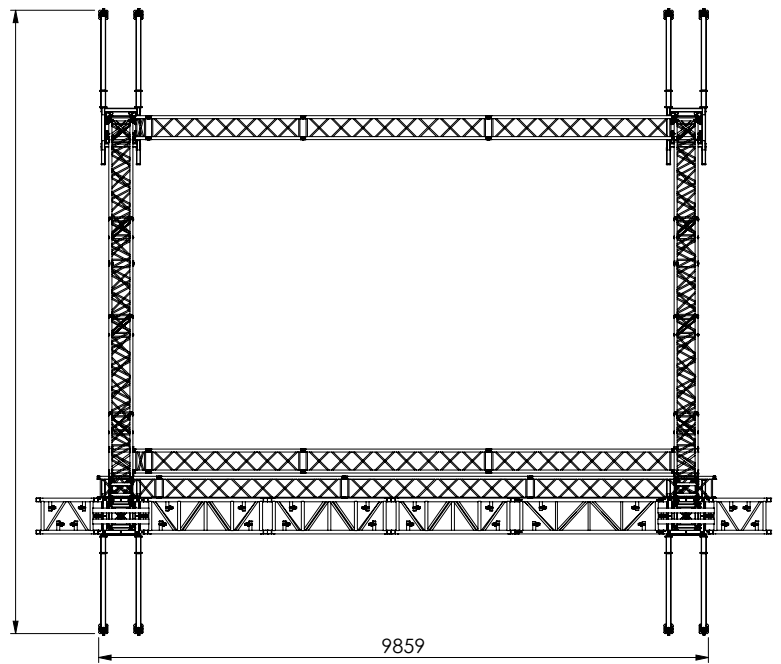

Top view

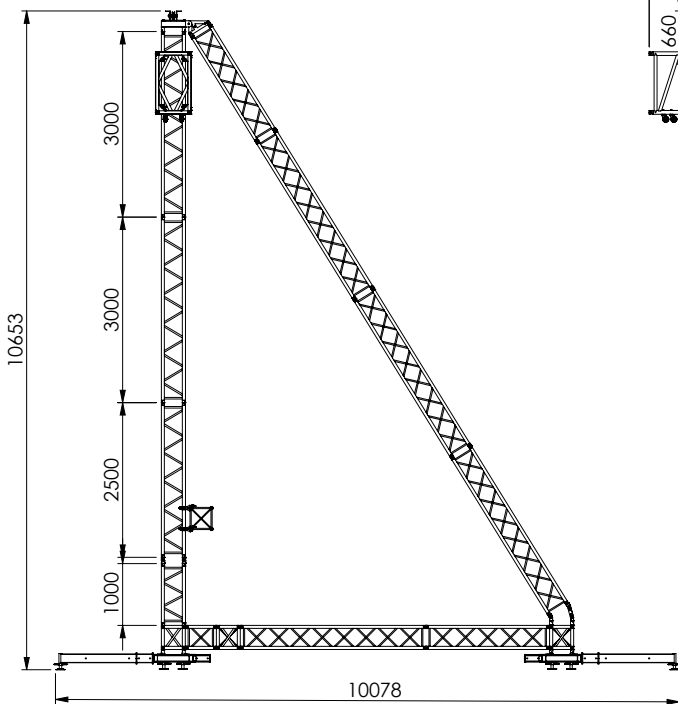

Right view

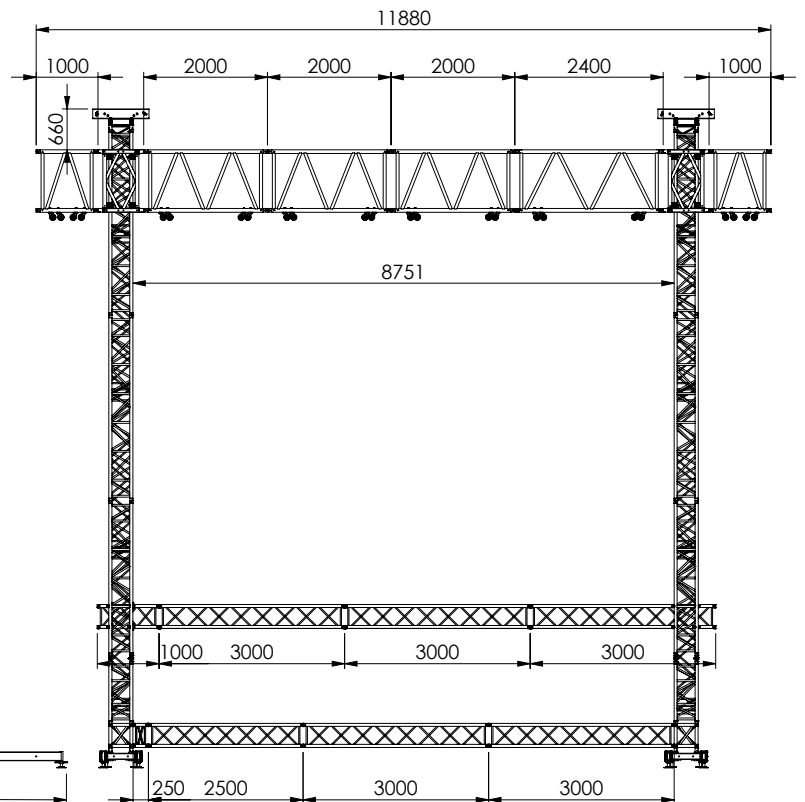

Back view



STAGE82	98
STAGE82 Model M	99
STAGE82 Model L	102
Stage Legs	105
Subframes	106
Arene Frame	109
Stage Accessories	117
Stairs Adjustable	118
Stairs Modular	119
Stage Railing	120
Skirting	121





Birch Plywood / Unfinished



Birch Plywood / Black

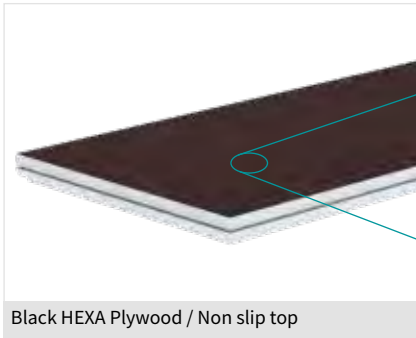

Black HEXA Plywood / Non slip top

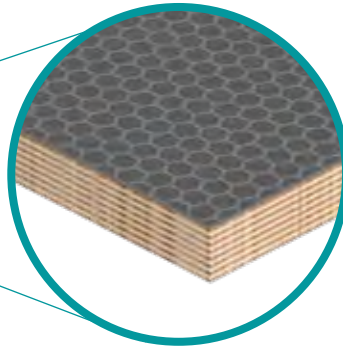

Scan the QR-Code
to watch the
technical video





WHY STAGE82 MODEL M?

- Frame design facilitates much easier handling and pick up by hand
- Scaffolding event beam compatible
- Double painted plywood topping



Leg Pocket closed

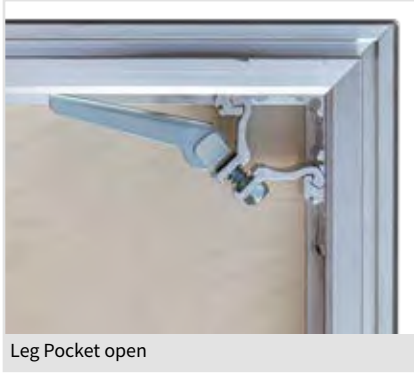

Leg Pocket open

- 750 kg/m²
- Lateral loading 10%
- Plywood 15 mm
- 36 kg (2 x 1 m)
- (RFID) READY



Easy grip profile

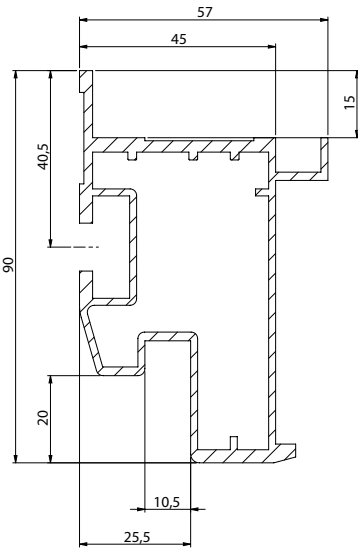

Rectangular 200 x 100 cm

Product	Code	Weight
Black HEXA Plywood / Non slip top	310001	35.68 kg
Birch Plywood / Black	311001	35.68 kg
Birch Plywood / Unfinished	312001	35.68 kg



Rectangular 100 x 100 cm

Product	Code	Weight
Black HEXA Plywood / Non slip top	310002	21.7 kg
Birch Plywood / Black	311002	21.7 kg
Birch Plywood / Unfinished	312002	21.7 kg

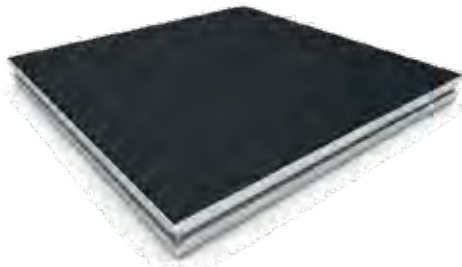

Rectangular 200 x 50 cm

Product	Code	Weight
Black HEXA Plywood / Non slip top	310003	21.17 kg
Birch Plywood / Black	311003	21.17 kg
Birch Plywood / Unfinished	312003	21.17 kg





200 x 100 cm **left** (3 legs needed)

Product	Code	Weight
Black HEXA Plywood / Non slip top	310005	20.7 kg
Birch Plywood / Black	311005	20.7 kg
Birch Plywood / Unfinished	312005	20.7 kg



Triangular 200 x 100 cm **right** (3 legs needed)

Product	Code	Weight
Black HEXA Plywood / Non slip top	310006	20.7 kg
Birch Plywood / Black	311006	20.7 kg
Birch Plywood / Unfinished	312006	20.7 kg



Triangular 100 x 100 cm (3 legs needed)

Product	Code	Weight
Black HEXA Plywood / Non slip top	310007	13 kg
Birch Plywood / Black	311007	13 kg
Birch Plywood / Unfinished	312007	13 kg



Circle 200 cm 90° (4 legs needed)

Product	Code	Weight
Black HEXA Plywood / Non slip top	310015	15 kg
Birch Plywood / Black	311029	15 kg
Birch Plywood / Unfinished	312016	15 kg



Circle 400 cm 45° (4 legs needed)

Product	Code	Weight
Black HEXA Plywood / Non slip top	310016	17 kg
Birch Plywood / Black	311030	17 kg
Birch Plywood / Unfinished	312017	17 kg



Circle 600 cm 22.5° (4 legs needed)

Product	Code	Weight
Black HEXA Plywood / Non slip top	310017	19 kg
Birch Plywood / Black	311031	19 kg
Birch Plywood / Unfinished	312018	19 kg





- Staging Modules must be used within the limits of the structural reposit
- Loading figures mentioned are only valid for static loads
- Self-weight is already taken into account

Maximum uniformly distributed load

Check alloy when legs are not purchased at SIXTY82

Podium height	80 cm (40 / 60 cm)	100 cm	120 cm	140 cm	160 cm
Tube 48.3 x 3 mm EN AW 6082 T6	750 kg/m ²	500 kg/m ²	500 kg/m ²	350 kg/m ²	350 kg/m ²

Maximum point load

LC1 = 2 x 150 kg at a distance of minimum 500 mm at any place

LC2 = 350 kg single point load above each of the 200 cm sides or middle beam

LC3 = 500 kg in the middle of the 100 cm sides

LC4 = 210 kg in the middle of an unsupported woodplate

Point loads need to have a 50 x 50 mm bearing surface minimum.

Total loading shall not exceed 1500 kg.

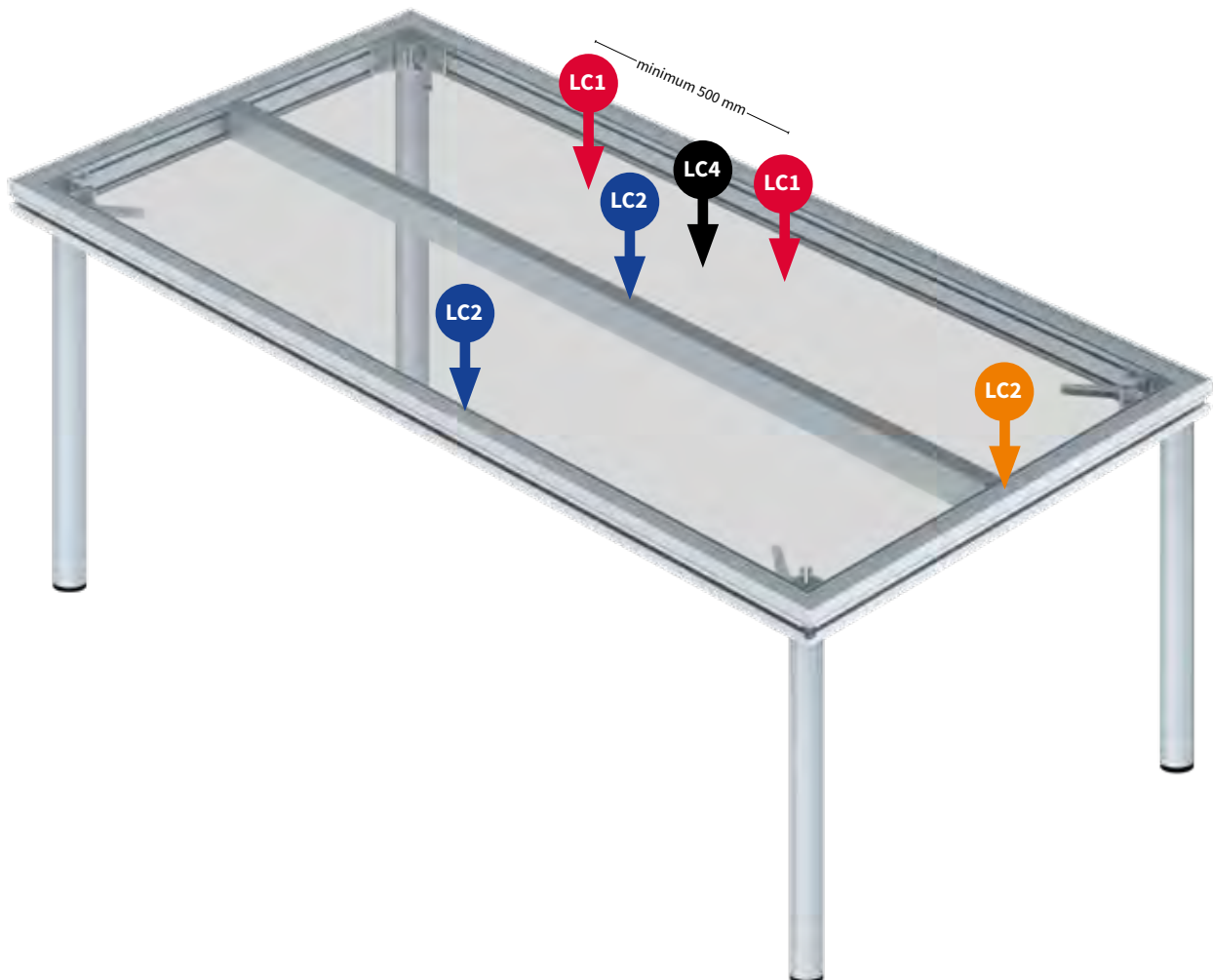



STAGE82 Model L

Imperial Sizes

WHY STAGE82 MODEL L?

- Frame design facilitates much easier handling and pick up by hand
- Scaffolding event beam compatible
- Double painted plywood topping



Leg Pocket closed



Leg Pocket open



610 kg/m²



Lateral loading 5%



Plywood 18 mm



65 kg (8 x 4 ft)



Easy grip profile

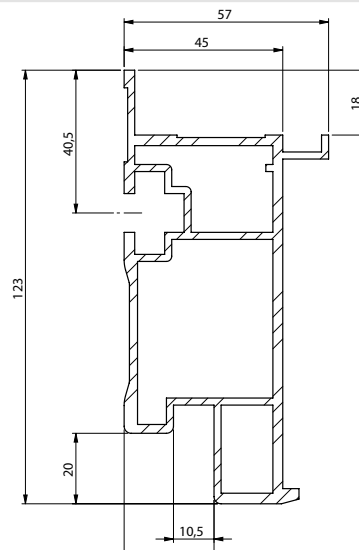

Rectangular 8 x 4 ft

Product	Code	Weight
Black HEXA Plywood / Non slip top	330001	65 kg
Birch Plywood / Black	331001	65 kg



Rectangular 8 x 2 ft

Product	Code	Weight
Black HEXA Plywood / Non slip top	330002	39 kg
Birch Plywood / Black	331002	39 kg



Rectangular 6 x 4 ft

Product	Code	Weight
Black HEXA Plywood / Non slip top	330003	52 kg
Birch Plywood / Black	331003	52 kg





Square 4 x 4 ft

Product	Code	Weight
Black HEXA Plywood / Non slip top	330004	39 kg
Birch Plywood / Black	331004	39 kg

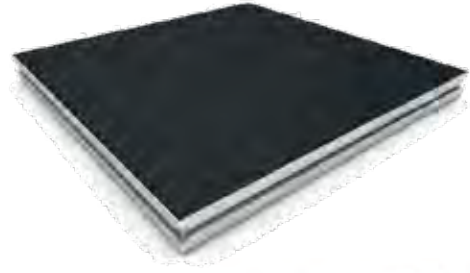

Rectangular 6 x 2 ft

Product	Code	Weight
Black HEXA Plywood / Non slip top	330005	31.2 kg
Birch Plywood / Black	331005	31.2 kg



Rectangular 4 x 2 ft

Product	Code	Weight
Black HEXA Plywood / Non slip top	330006	23.4 kg
Birch Plywood / Black	331006	23.4 kg



Square 2 x 2 ft

Product	Code	Weight
Black HEXA Plywood / Non slip top	330007	14.4 kg
Birch Plywood / Black	331007	14.4 kg



Triangular 4 x 4 ft

Product	Code	Weight
Black HEXA Plywood / Non slip top	330008	26.4 kg
Birch Plywood / Black	331008	26.4 kg

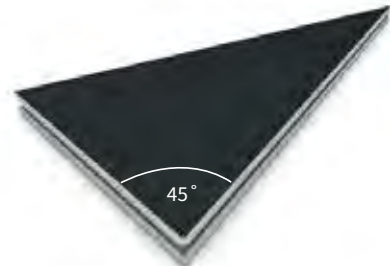



LEG

Code	Length (H)	Weight
340001	20 cm	0.23 kg
340002	40 cm	0.46 kg
340003	60 cm	0.69 kg
340004	80 cm	0.93 kg
340005	100 cm	1.16 kg

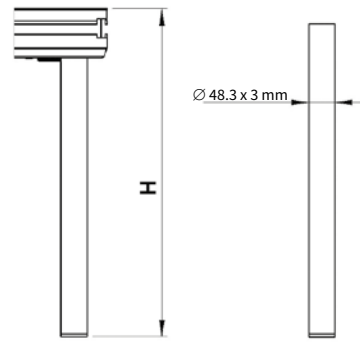
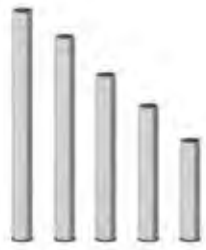

ADJUSTABLE LEG

Code	Length (H)	Weight
340007	20 cm	0.27 kg
340008	40 cm	0.49 kg
340009	60 cm	0.72 kg
340010	80 cm	0.95 kg
340011	100 cm	1.18 kg

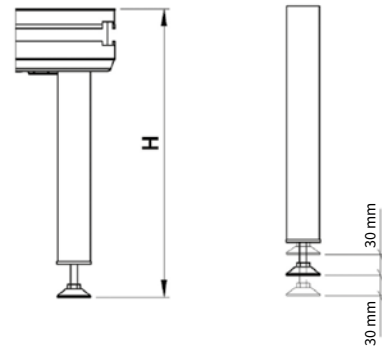
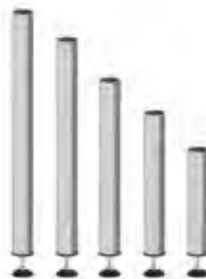

TELESCOPIC LEG

Code	Length (H)	Weight
340077	40 / 60 cm	1.4 kg
340080	60 / 100 cm	2.51 kg
340015	90 / 140 cm	3.57 kg
340016	100 / 160 cm	4.22 kg
340017	120 / 190 cm	5.1 kg

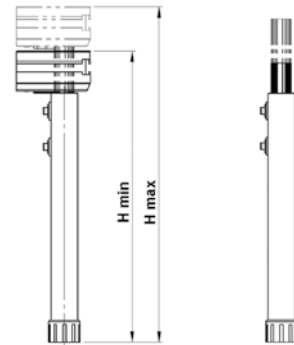

SWIVEL CASTOR LEG SINGLE

Code	Length (H)	Weight
340018	25 cm	1.35 kg
340029	40 cm	1.45 kg
340041	60 cm	1.65 kg
340033	80 cm	1.8 kg
340023	100 cm	1.99 kg



SWIVEL CASTOR LEG DOUBLE

Code	Length (H)	Weight
340019	25 cm	1.75 kg
340030	40 cm	2.09 kg
340057	60 cm	2.3 kg
340059	80 cm	2.45 kg
340060	100 cm	2.65 kg





Subframe B

Product	Code
Leg Subframe B120 Stage82	341004
Rack Subframe B120 Stage82 200 x 120 cm	341005
Rack Subframe B120 Stage82 100 x 120 cm	341006
Leg Subframe B160 Stage82	341007
Rack Subframe B160 Stage82 200 x 160 cm	341008
Rack Subframe B160 Stage82 100 x 160 cm	341009
Leg Subframe B200 Stage82	341010
Rack Subframe B200 Stage82 200 x 200 cm	341011
Rack Subframe B200 Stage82 100 x 200 cm	341012
L-Pin 16x70 drop nose	811033
Scaff Spindle 60 cm	251009

WHY SUBFRAME B?

- For STAGE82
- For indoor and outdoor use
- Easy to level
- Extremely easy and fast to build and use
- Adjustable in height
- Integration in roof systems (can replace ground ring)
- Made by reinforced profile
- Internal diagonals integrated
- No adapters needed
- Offers space for ballast
- Rigid construction: can be calculated as ballast weight

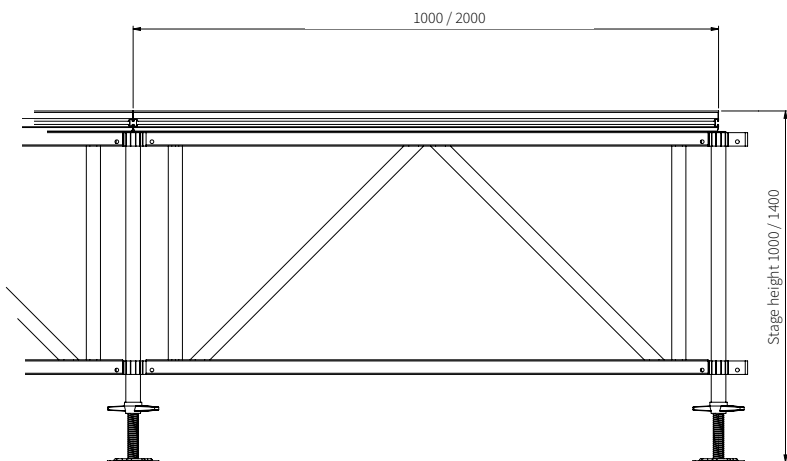

750 kg/m²

Lateral loading 10%

Stage height

120 cm	160 cm	200 cm
100 to 140 cm	140 to 180 cm	180 to 220 cm

All frames are available in 0.5, 1 and 2 meter

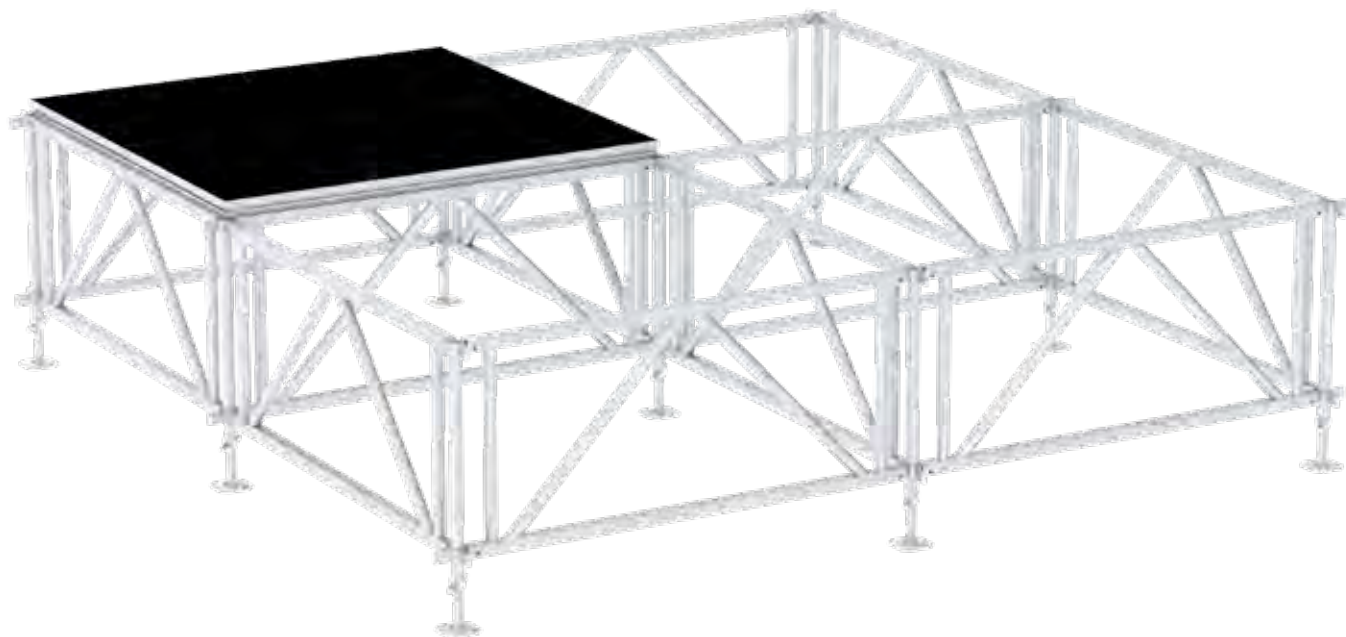

No adapters needed

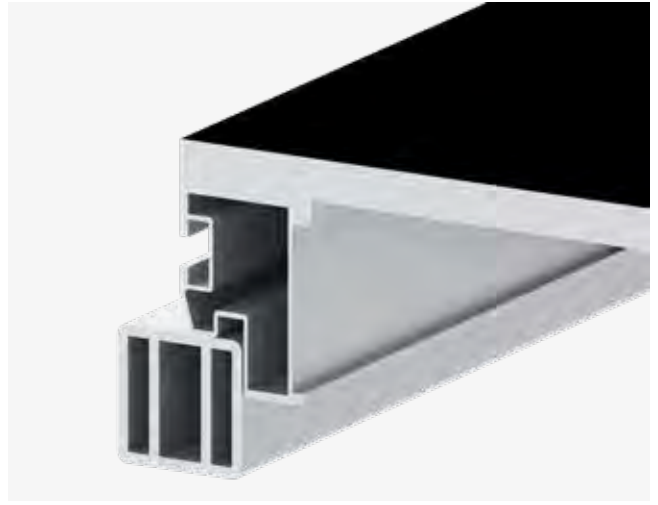

cross section view



Scan the QR-Code
to watch the STAGE82
technical video

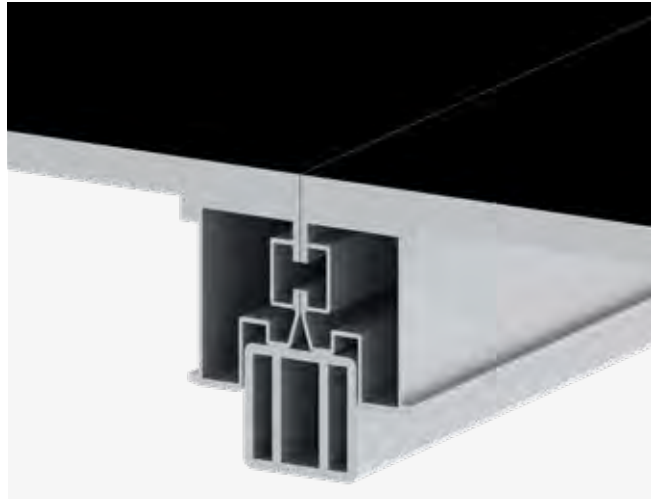



ARENA FRAME

A large, multi-level metal arena frame structure is shown in an industrial setting. The structure is composed of numerous vertical and horizontal metal beams, forming a complex, multi-tiered framework. A prominent feature is a set of stairs with metal railings that lead up to one of the higher levels. The structure is supported by a base that includes several casters or wheels, suggesting it is designed to be mobile. The background is dark and out of focus, emphasizing the metallic structure in the foreground.

WORLDWIDE PATENT

Sixty82 launches the new Arena Frame

This new concept is designed for venues which value the benefits of a quick and easy to build stage system. The straightforward design allows big stages to be built in the blink of an eye. A 200 square meter stage can be built in 90 minutes with a crew of 4 and a forklift. Because the frames are foldable, the system has a very small storage footprint. The ability to build the stage and rig at the same time greatly lowers the time needed to build any stage set.

4-way adapter

- One size fits all Adapter
- All different configurations can be made with the 4 way adapter
- Rotatable in 4 orientations

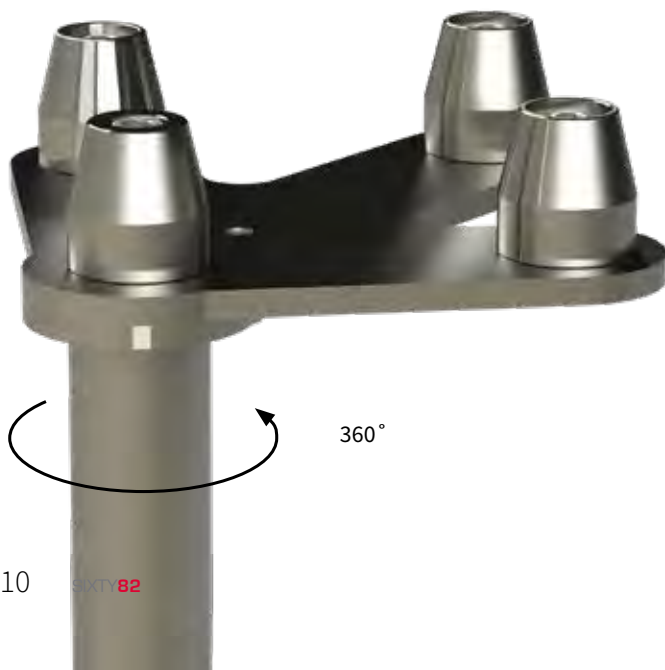

World's fastest big stage system



Easy to use, no tools needed



Flexible in size and height



No loose parts, all configurations can be made with the same frames



Easy to store - small footprint



Entire stage is movable as one, this allows you to build the rig and stage at the same time



Scan the QR-Code
to watch the ARENA FRAME
technical video



Scan the QR-Code
to watch the ARENA FRAME
building video

4 way-adapter

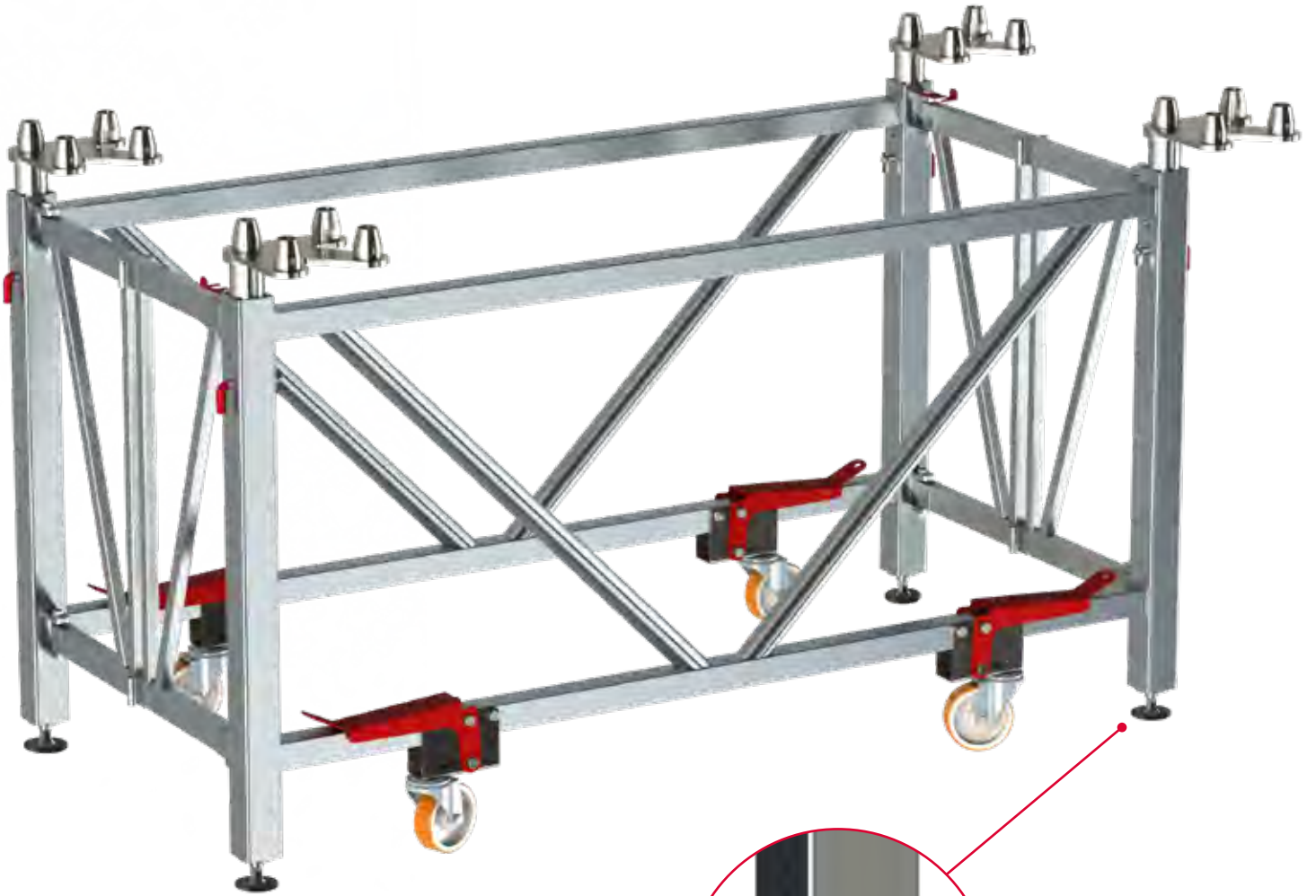

Level your stage

Stage can be perfectly stabilized using the adjustable feet



Rock solid structure

The unique brake system highly increases the stability of the stage.

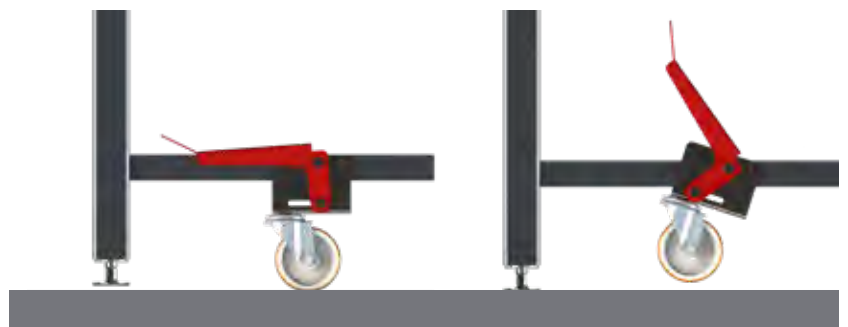

Easy to assemble



Three Frame Types

Single, double, and triple frames (to make even and uneven sized stages).

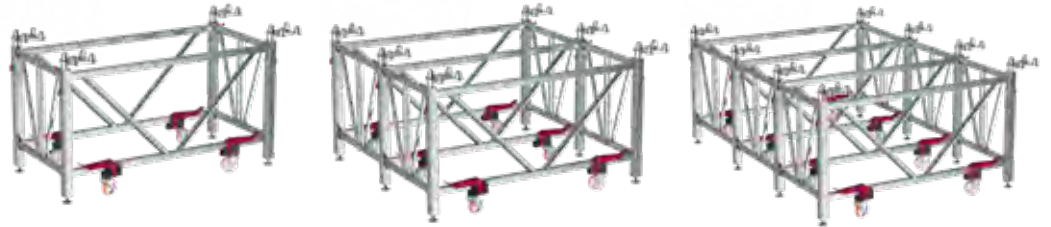

Available in Two Height Systems

Pre-assembled frames can be adjusted in height:
80 - 120 cm (32 - 48")
120 - 190 cm (48 - 78")
Both systems adjust in steps of 5 cm (2").



Foldable frame

Easy to store, the folding frame creates a small footprint.



Metric size

To be used in combination with **model M stagemodules**, page 99.

SINGLE	
Code	Height
341043	80 - 120 cm
341014	120 - 190 cm



DOUBLE	
Code	Height
341044	80 - 120 cm
341015	120 - 190 cm



TRIPLE	
Code	Height
341049	80 - 120 cm
341050	120 - 190 cm

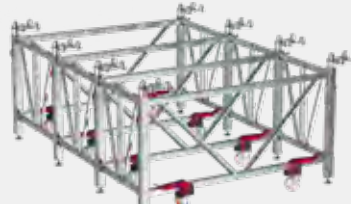

Imperial size

To be used in combination with **model L stagemodules**, page 102.

SINGLE	
Code	Height
341051	32 - 48"
341030	48 - 78"



DOUBLE	
Code	Height
341052	32 - 48"
341031	48 - 78"



TRIPLE	
Code	Height
341053	32 - 48"
341032	48 - 78"



Arena Frame accessories

Stage82 Arena adapter Rack 40pcs

215046

113 kg



Arena frame Grounding-Kit

341028

43.36 kg



Skirting Arena Frame 220x190cm ADJ

360084

1.68 kg



Dolly arena frame forklift handling 6SF 4DF 2TF

215029

116 kg



Dolly arena frame stackable forklift 6SF 4DF 2TF

215045

395 kg



Dolly skirting profiles and skirts

215049

70 kg



Stair Arena Frame 120-190

351027

267 kg



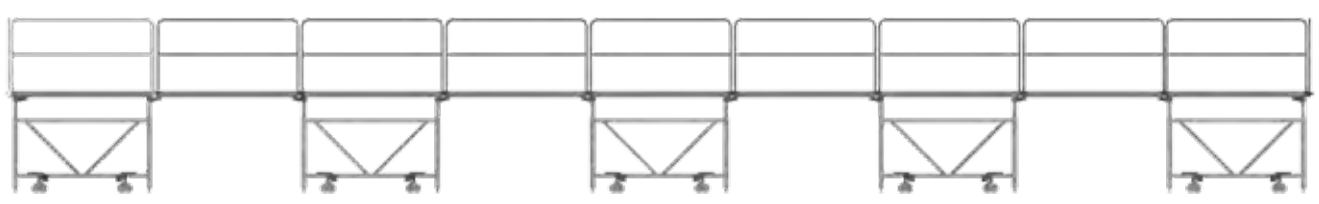
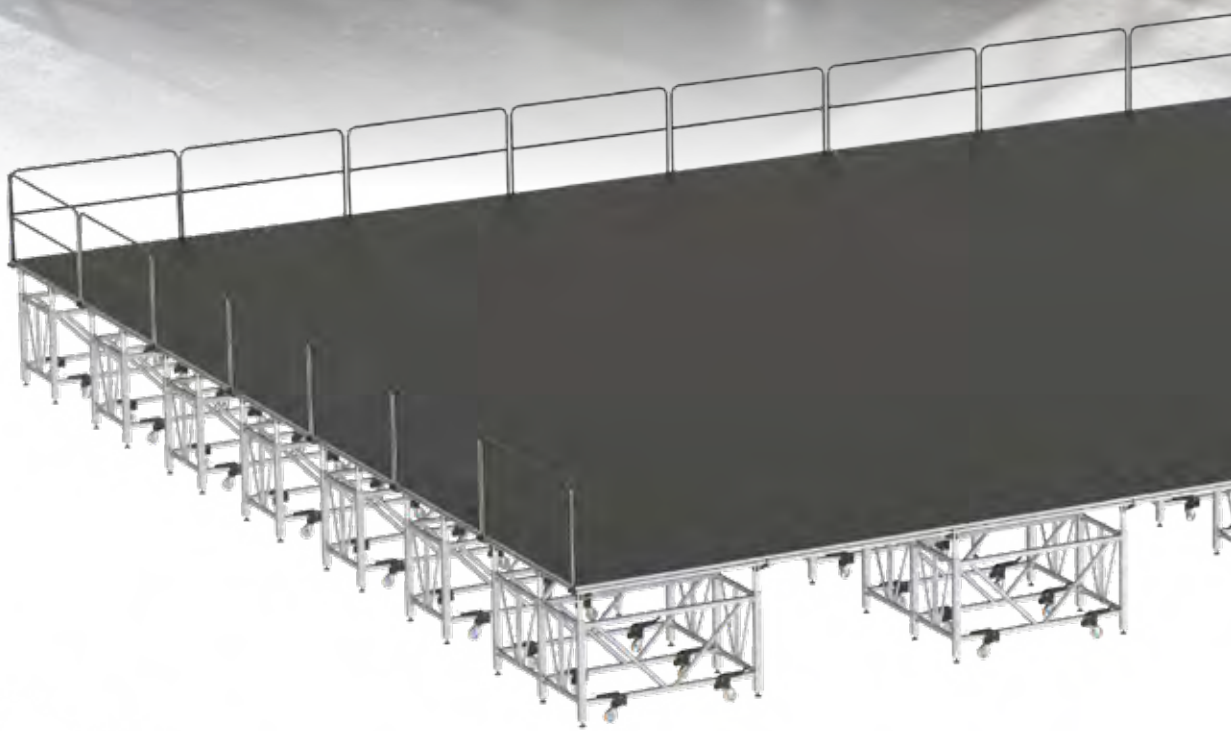

WHY: ETP multi-clamp

360035

- Most stable design in the market
- Suitable for STAGE82 (48mm diameter legs)
- 1 position for interlocking legs when staging modules are at level
- 1 position for interlocking legs when staging modules are at different levels
- Can be used to connect vertical poles to the legs
- Full aluminium
- Easy to mount

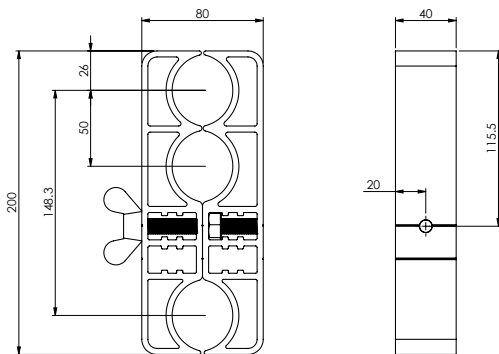

LEG-TO-LEG

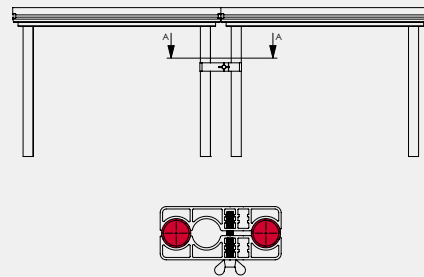

GRAND-STAND

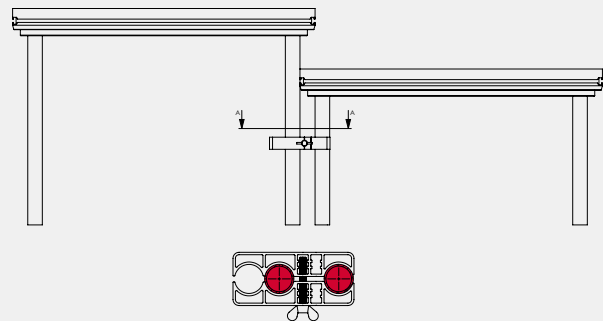

LEG-TO-POLE

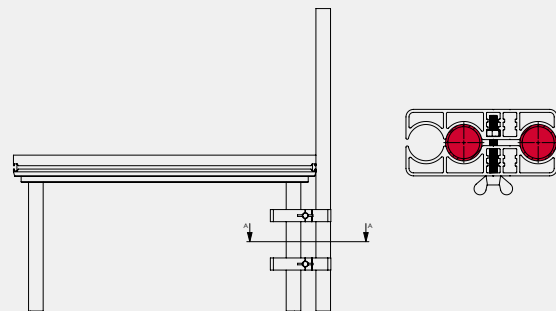

Scan the QR-Code
for more information

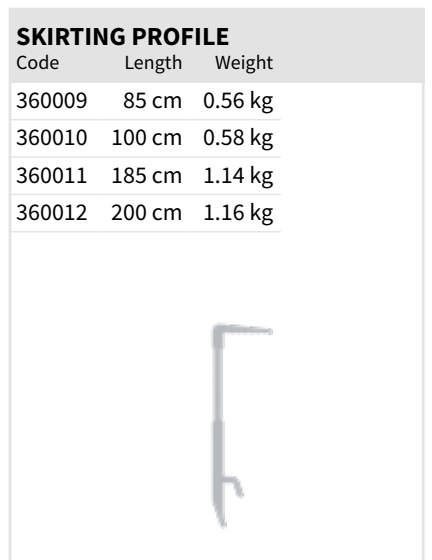
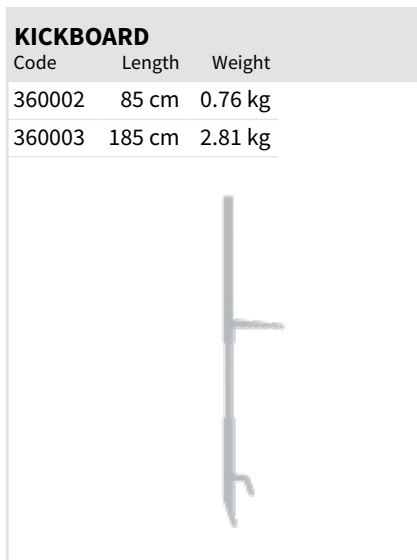
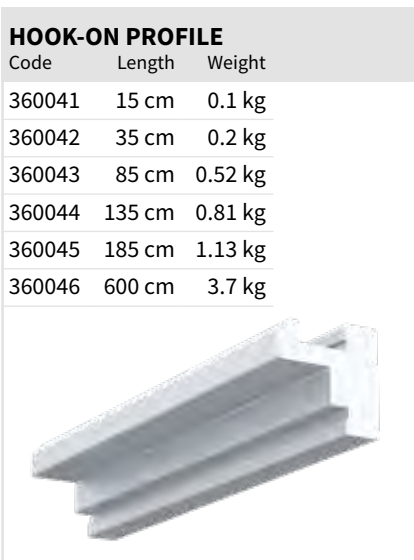
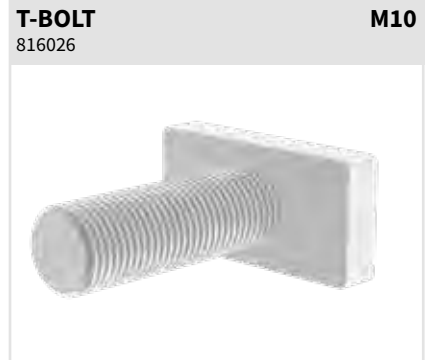
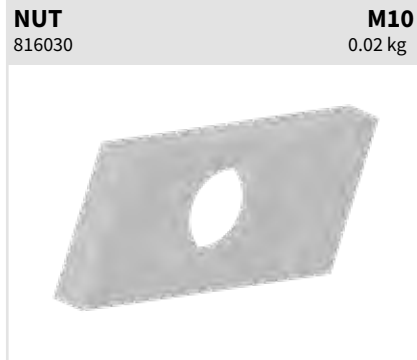
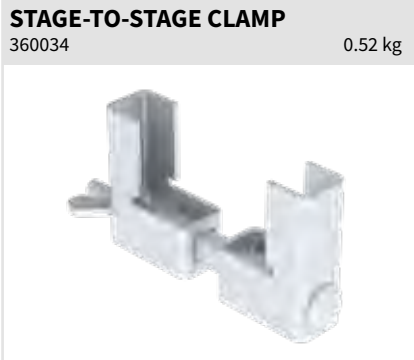



	4 STEPS	5 STEPS
Height	min 40 cm / max 100 cm	min 50 cm / max 120 cm
Width overall	835 mm	835 mm
Load per step	150 kg	150 kg
Uniformly distributed load m ²	500 kg	500 kg
Weight	17.8 kg	21.6 kg
Article number	351015	351016



WHY STAIRS ADJUSTABLE?

- Fits to all stage modules of SIXTY82
- Integrated fixation system
- Steps with anti slip surface
- Full aluminium structure
- Flush out side for ease of transport
- Low self weight
- Use M10x50 (816035 + 816010) for assembly to LITE82

Assembly

NUT M10
816030



for STAGE82

Bolt M10x14 DIN912 (816059)

Handrail

HANDRAIL 4-5 STEPS

351017

8.5 kg

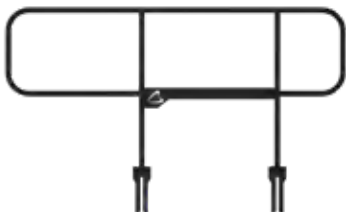

Can be used on both sides of stairs

Including accessories





WHY STAIRS MODULAR?

- Fits to all stage modules of SIXTY82
- A single step unit, one-size fits all
- Bolted together to create stair height up to 140 cm
- Ideal for transport: optimised packaging volume due to flat-pack-design
- Anti-slip Steps
- Loading 500 kg/m²
- Protected front edge of steps
- Integrated handrail connection

Every element of modular stairs has a total height of 40cm, when mounted properly the height of the stairs will increase with steps of 20 cm.

The formula to calculate the amount of elements needed is:

$$\text{height of stage in cm} / 20 = \dots - 1$$



Handrail

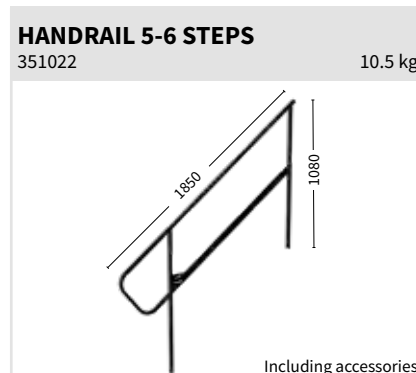
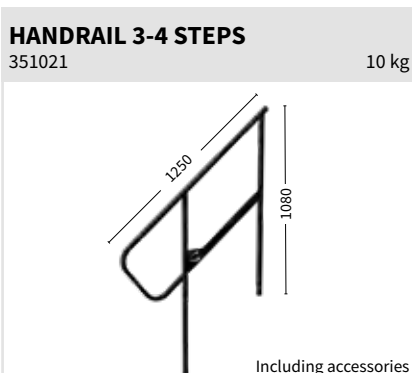

Assembly





STAGE82

STAGE RAILING

350005

30 KG/M

7.34 kg

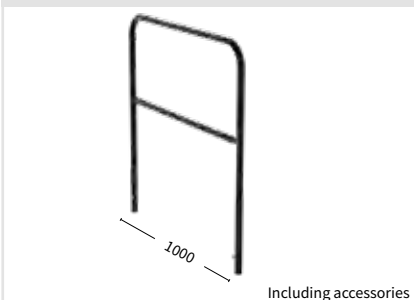

Including accessories

STAGE RAILING

350006

30 KG/M

11.46 kg

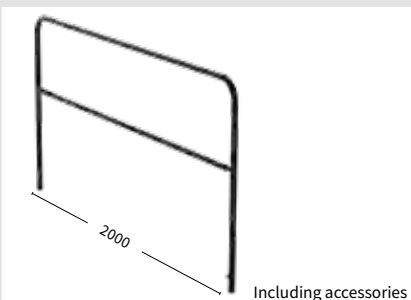

Including accessories

RAILING SPACER

351013

0.01 kg



Bolt M10x110 (816019) + wing nut M10 (816020)

STAGE RAILING ADJUSTABLE

350021

8 kg

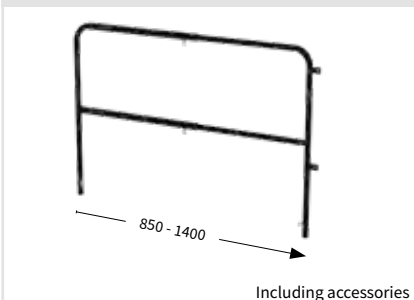

Including accessories

STAGE RAILING ADJUSTABLE

350022

10 kg

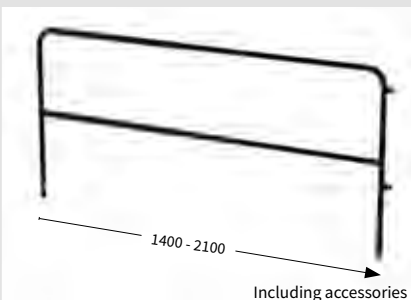

Including accessories

CORNER FIX RAILING

350036

0.5 kg



RAILING SPIGOT

350023

0.7 kg



RAILING SPIGOT CORNER

350024

1.7 kg



SKIRT STRAIGHT FINISH		Polyester 160 g/m ² - B1
Code	Length	
360013	20 x 100 cm	
360014	40 x 100 cm	
360015	60 x 100 cm	
360016	80 x 100 cm	
360017	100 x 100 cm	
360018	20 x 200 cm	
360019	40 x 200 cm	
360020	60 x 200 cm	
360021	80 x 200 cm	
360022	100 x 200 cm	

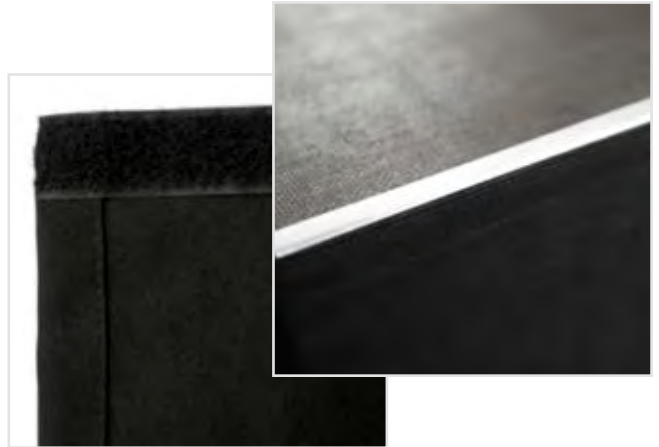

SKIRT PLEAT FINISH		Polyester 160 g/m ² - B1
Code	Length	
360023	20 x 100 cm	
360024	40 x 100 cm	
360025	60 x 100 cm	
360026	80 x 100 cm	
360027	100 x 100 cm	
360028	20 x 200 cm	
360029	40 x 200 cm	
360030	60 x 200 cm	
360031	80 x 200 cm	
360032	100 x 200 cm	





Photographer: Syo van Vliet

Tube	124
Booth82	125
Truss Dolly	126
Base Plate Dolly	127
Vario Dolly	128
Crate Dolly	129
Stage Dolly	130
Railing Dolly	131
Lighting Pods	132





TUBE

Code	Length
225001	50 cm
225002	75 cm
225003	100 cm
225006	150 cm
225004	200 cm
225007	250 cm
225005	300 cm
225008	400 cm



ø 48.3 x 3

TUBE CONICAL COUPLER

Code	Length	Weight
221001	50 cm	0.75 kg
221002	75 cm	0.98 kg
221003	100 cm	1.33 kg
221006	150 cm	2 kg
221004	200 cm	2.48 kg
221007	250 cm	3.03 kg
221005	300 cm	3.63 kg
221008	400 cm	4.78 kg



ø 48.3 x 3

TOP CIRCLE M29S + M39S

229003

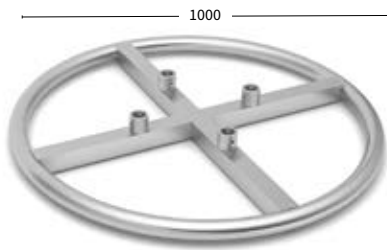

Excluding accessories

TUBE CONICAL COUPLER BLACK

Code	Length	Weight
221201	50 cm	0.75 kg
221202	75 cm	0.98 kg
221203	100 cm	1.33 kg
221206	150 cm	2 kg
221204	200 cm	2.48 kg
221207	250 cm	3.03 kg
221205	300 cm	3.63 kg
221208	400 cm	4.78 kg



ø 48.3 x 3

CUBE M BLACK

202445

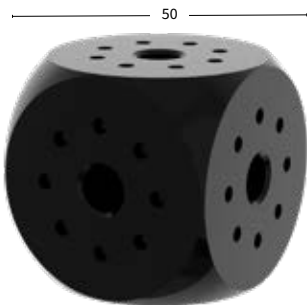



WHY BOOTH82?

- Very compact & light
- Beautiful appearance
- Multi-useable
- Is used in combination with STAGE82
- Easy to transport
- Easy to assemble (one man's job)

BOOTH82
700134

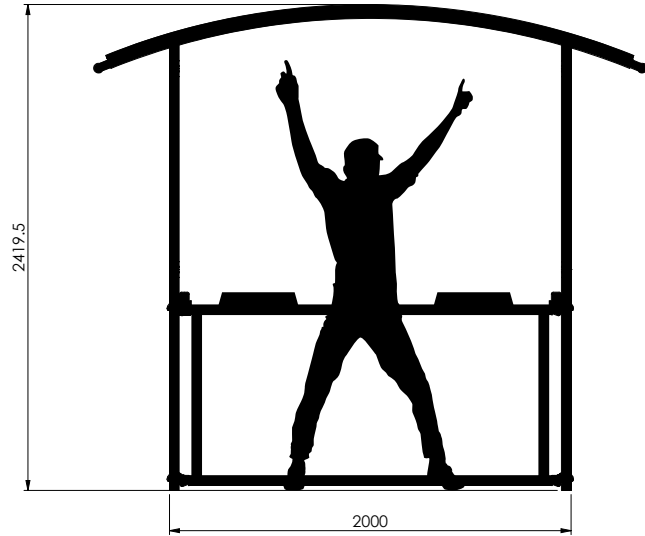

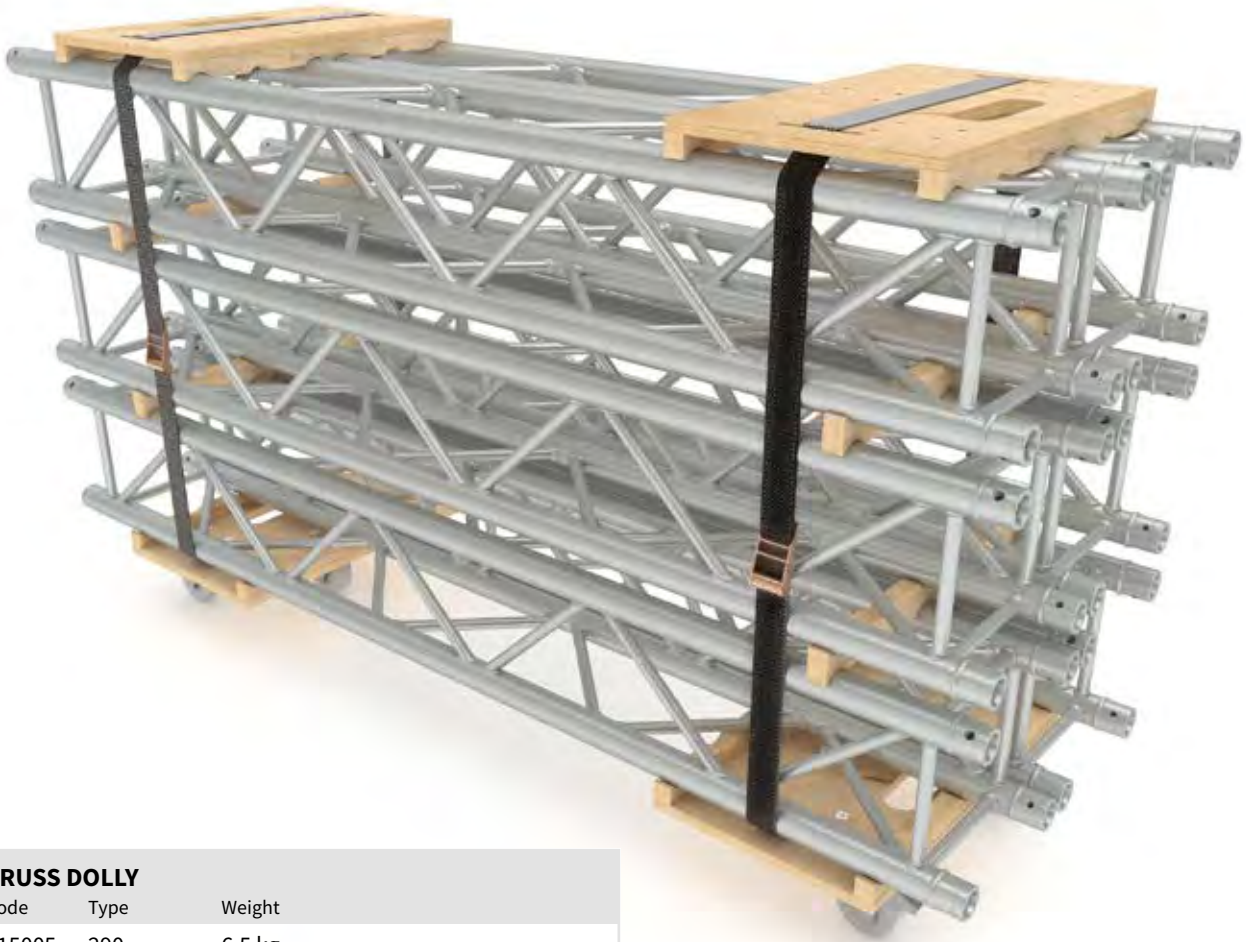

TRUSS DOLLY

Code	Type	Weight
215005	290	6.5 kg
215006	390	7.3 kg



STACKING BAR DOUBLE

Code	Type	Weight
215003	M29	1.8 kg
215004	M39	2.5 kg



STACKING BAR

Code	Type	Weight
215001	M29	0.5 kg
215002	M39	0.7 kg



BASE PLATE DOLLY
215011

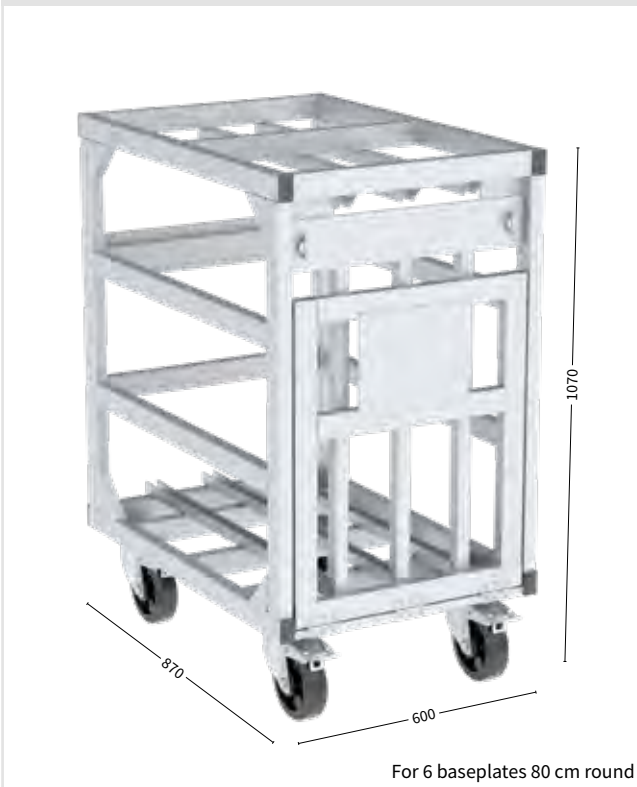

BASE PLATE DOLLY
215012





VARIO DOLLY 4-3H

215007



VARIO DOLLY 4-4H

215008



TUBE

215015

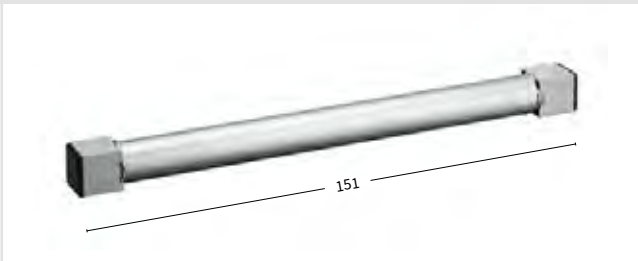

LOCKING PIN

215014



SUSPENSION BRACKET

215017



CRATE

215016

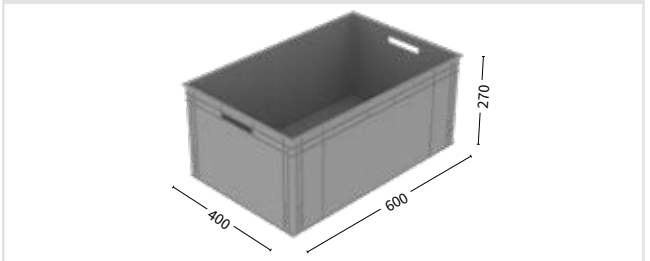

TOP CRATE

215010



CRATE DOLLY

215009



WHY crate dolly

215009

- Easy on the road storage system
- Endless possibilities
- Can be ordered in many possible configurations
- Crates can not fall out during transport (locking system)
- Available with handles
- Top crate and countertop available
- Including wheels and brakes-system
- Size of DOLLY: from 1x2 till 4x4 crates
- Different size and type of crates
- Light in use



Scan the QR-Code
to watch the Crate Dolly
technical video

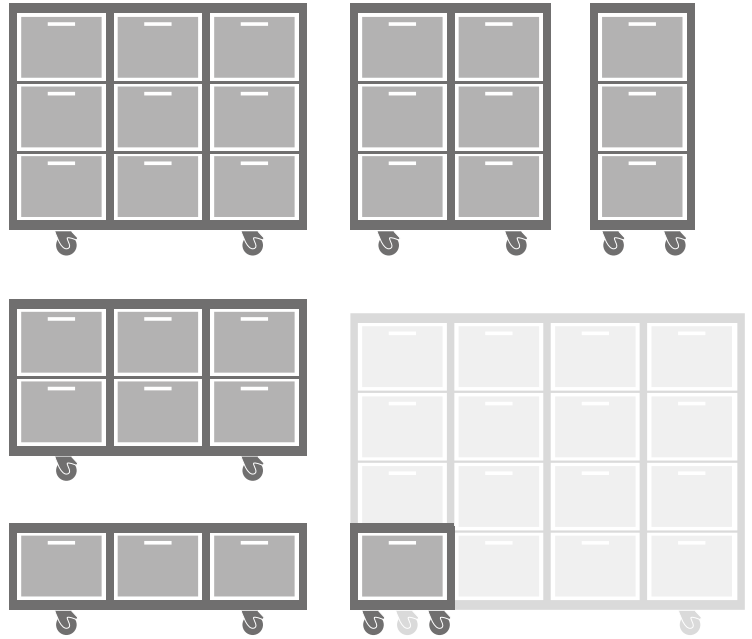



STAGE DOLLY
215018

48.5 kg



For 12 stage modules M

STAGE DOLLY
215020

41.9 kg



For 6 stage modules M



RAILING DOLLY
215022

52.8 kg



For 12 railings of 2 meter or 24 railings of 1 meter

For railing 30 kg/m



Accessories not included



Lighting Pods

A Smart Solution for Load-Bearing, Transport, and Creative Design

The Sixty82 **Lighting Pods** are a cool addition to our product line, offering a versatile solution for the storage, transport, and deployment of lighting fixtures. These pods are designed specifically for AV rental and touring companies, serving as both practical load-bearing dollies and as part of the show's design elements. They combine functionality and style to meet the demands of dynamic productions.

Key Features:

- **Fixed Dimensions:** Each pod stands at a height of 190 cm and a depth of 80 cm, ensuring uniformity and ease of integration.
- **Connectivity:** The Lighting Pods can be connected both vertically and sideways, offering flexible design possibilities.
- **Customizable Shapes:** Achieve unique configurations with various sizes and suspension plates tailored to your specific needs.
- **Heavy-Duty Design:** Built to withstand rigorous use, the pods come equipped with black wheels and integrated fork-lift points for effortless mobility and handling.
- **Multiple Widths:** Available in 210 cm, 157.5 cm, and 105 cm to suit diverse applications.
- **Adjustable Suspension Tubes:** Add as many suspension tubes as required, with adjustable height settings for precise placement.
- **Integrated Ladder:** A ladder at the back of each pod ensures convenient access during setup and operation.

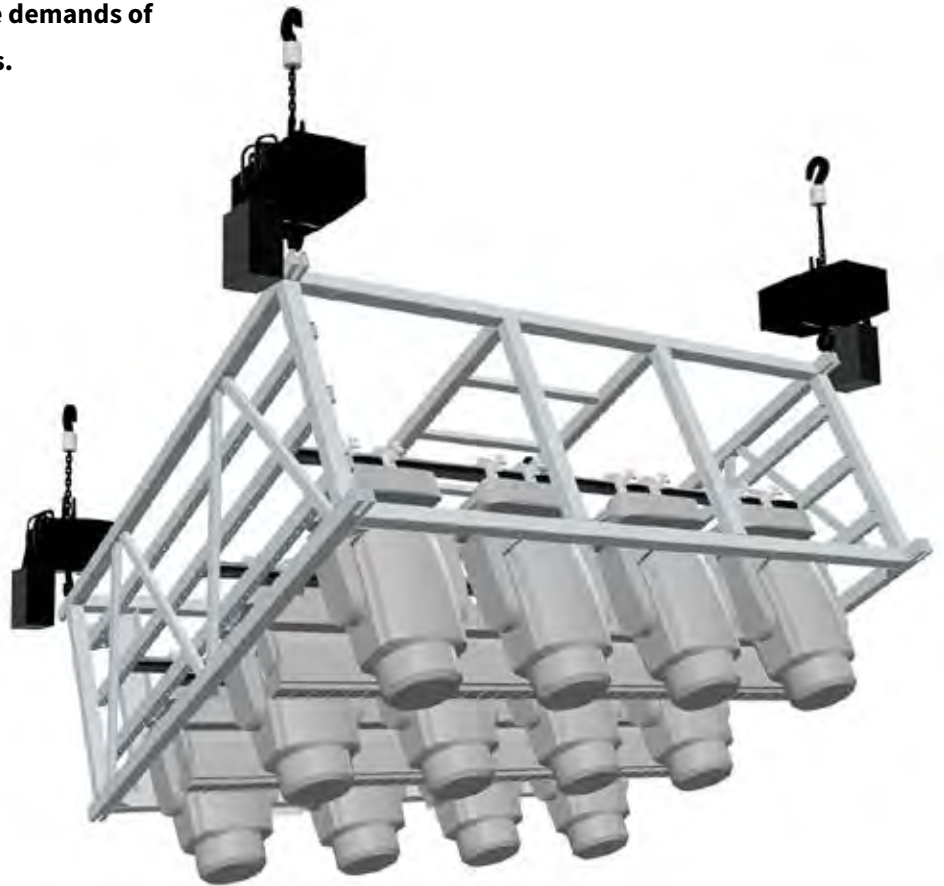

Applications

The Lighting Pods excel as storage and transport solutions for lighting fixtures and set pieces. They can also serve as pre-rig setups, streamlining installation and reducing setup time. Additionally,

their sleek and modular design allows them to become integral parts of the show, adding visual appeal to the production

LIGHTING POD 1050
217103



LIGHTING POD 1575
217102



LIGHTING POD 2100
217101



All Lighting Pods are Powder Coated in Black (RAL 9005).

Asseccories

LIGHTING POD SUSPENSION STRIP
217104



2 x 811003

LIGHTING POD COUPLING STRIP
217105



3 x 811003

LIGHTING POD SUSPENSION TUBE

Code	Product
217106	Suspension tube 2100
217107	Suspension tube 1575
217108	Suspension tube 1050

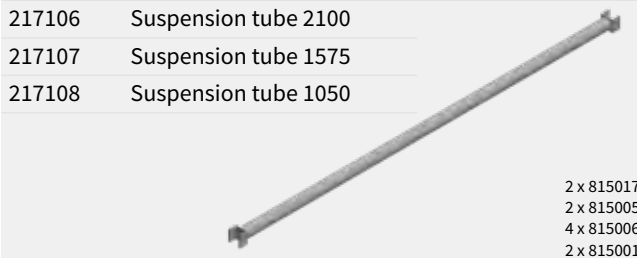

2 x 815017
2 x 815005
4 x 815006
2 x 815001

The Lighting Pods can be connected both vertically and sideways, offering flexible design possibilities.

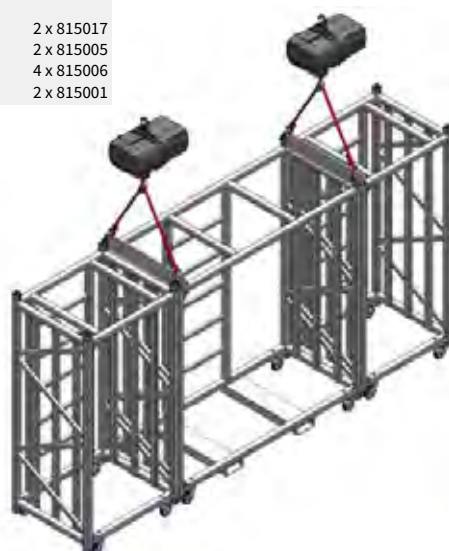

INFERNO®:

The Heat Resistant Soft Sling

The **INFERNO®** soft sling is made of 100% aramid fibre and therefore ultra heat resistant. This is the same material used in firefighter suits. The nature of the fibre provides a sling that is extraordinary flexible and therefore much easier to handle compared to a soft steel particularly when slinging truss. The label is movable along the sling and will therefore no longer interfere with proper choking or wrapping of truss chords. The **INFERNO®** has a WLL of 2000 kg and comes in standard length of 50 cm, 100 cm, 150 cm and 200cm.



Features

- Maintains its strength up to 200 °C(!)
- Easy to position
- Minimum bending radius 6 mm
- Soft, supple, light weight and easy to handle
- Improves workflow
- High abrasion resistance
- Environmentally friendly due to the long-life span
- Creates safer lifting conditions
- Easy to inspect
- Made in The Netherlands
- Custom working loads and lengths optional

Article code	Description
241050	Inferno Soft sling 50 cm WLL 2000kg
241051	Inferno Soft sling 100 cm WLL 2000 kg
241052	Inferno Soft sling 150 cm WLL 2000 kg
241053	Inferno Soft sling 200 cm WLL 2000 kg



Scan the QR-Code
for more information

User information

Suggested slinging methods

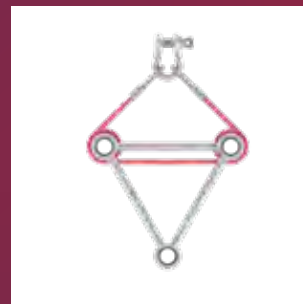
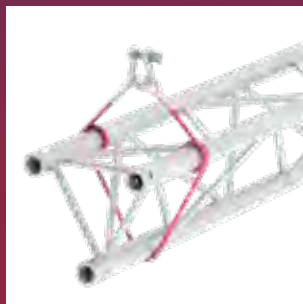
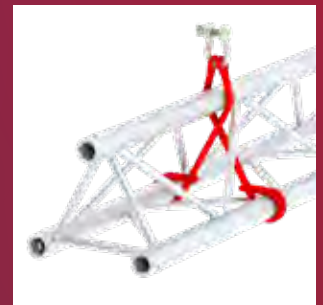
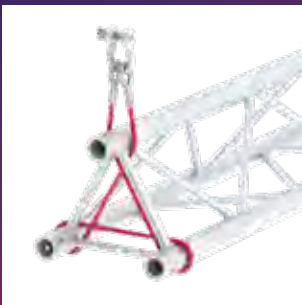
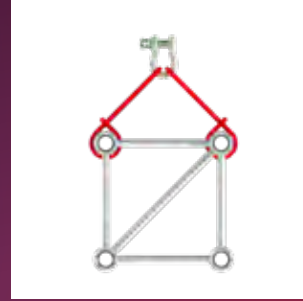
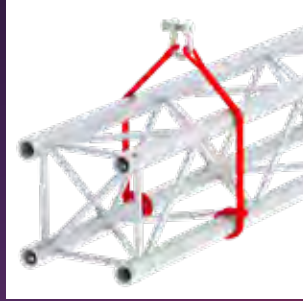
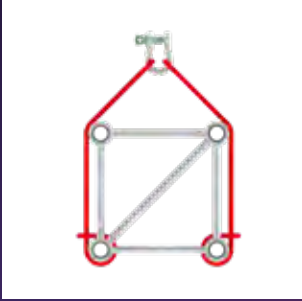

Ladder truss

These need special attention for slinging. Stabilisation of the top chord is vital for the load capacity. Only the bottom chord shall be loaded. Other load applications need structural analysis before use.



Slinging shall be applied solely at the main chords, not at the couplers or internal braces unless approved by a chartered engineer. Slinging shall be applied at node point, or as close as possible aside end braces, diagonals, and horizontal cross braces. Slinging equipment shall be made from non-abrasive and fire retardant materials.

For further information, please refer to the SIXTY82 original user manual.



Data Center

Type	Coupler type	Truss height	Truss width	Material	Cross section tubes				Dead weight	RFID
					Main chord		Diagonals			
					∅ mm	≠ mm	∅ mm	≠ mm		
TPM29T	Model M	207	239	EN AW 6082 T6	48.3	3	17x14	2.45/1.7	5.5	✓
TPM29S		239	239		48.3	3	17x14	2.45/1.7	6.4	
(TP)M29L		239	0		48.3	3	16	2	3	
TPM39S (MB)		339	339		48.3	3	22x16	2.6x1.7	6.9	
M29T		207	239		48.3	3	16	2	5	
M39TOW		339	339		50	4	25	3	12	
L52S (MB)	Model L	470	470		50	4	30	3	15	✓
XL53TOW		470	470		60	5	30	3	17.5	
XL101R	Model XL	950	520		60	6	48.3	3	25	✓
XL101F		950	520		60	6	48.3	3	25	

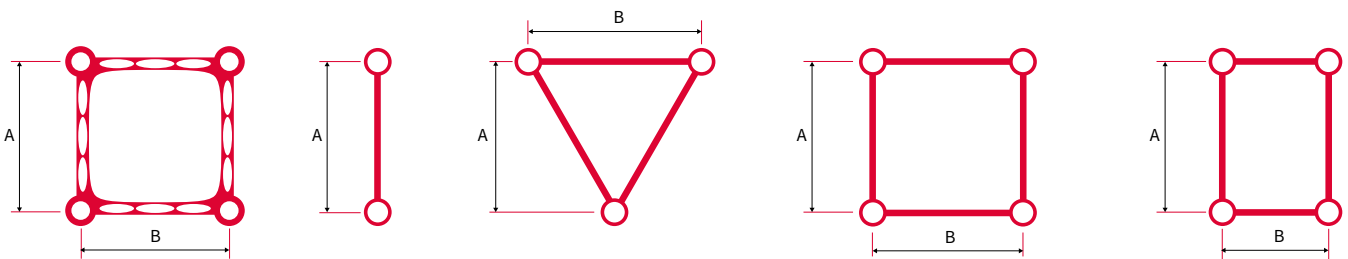

Type	Cross section truss					Permissible internal forces truss				
	A cm ²	I _y cm ⁴	I _z cm ⁴	I _y cm	I _z cm	Bending moment		Normal force N kN	Transversal force	
						My kNm	Mz kNm		V _y kN	V _z kN
TPM29T	12.81	1252.60	1252.37	9.89	9.89	12.19	14.08	176.70	16.02	18.5
TPM29S	17.08	2482.74	2482.74	12.06	12.06	25.83	25.83	216.19	18.5	18.5
(TP)M29L	8.54	1055.16	22	11.12	1.61	12.08	-	101.1	-	7.36
TPM39S (MB)	17.08	4950.46	4950.46	15.7	15.7	36.64	36.64	216.19	23	23
M29T	12.81	1064.71	1064.71	9.12	9.12	10.46	12.08	151.65	7.36	12.76
M39TOW	23.12	5698.96	5500	15.7	15.42	36.06	36.06	212.77	40.22	40.22
L52S	23.12	10906.19	10906.19	21.72	21.72	64.33	64.33	273.77	42.61	42.61
XL53TOW	34.6	16334	16334	21.74	21.74	96.15	96.15	409.16	42.61	42.61
XL101R	40.72	78211.52	23522.57	43.83	24.04	224.32	122.79	472.26	42.54	90.48
XL101F	-	78211.52	-	43.83	-	224.32	-	472.26	-	86.61



Custom Projects

Innovative Custom Designs

At SIXTY82, we specialize in transforming ideas into reality. Whether it's a unique stage setup, a complex truss system, or a permanent installation, our custom designs deliver unmatched creativity and functionality.

Engineering Precision

Our in-house engineering team combines deep expertise with cutting-edge technology. From initial concept to structural analysis, we ensure every design meets the highest standards of safety and precision.

Building the Project Together

We believe great projects are built on great partnerships. By working closely with you throughout the process, we ensure your vision is fully realized, on time and on budget.

Tailored Solutions

No two projects are the same. That's why we offer fully tailored solutions, adapting our designs to meet your specific needs and objectives, no matter how complex they may be.





Quality You Can Trust

Every structure we build undergoes rigorous testing to guarantee durability, safety, and exceptional performance. With SIXTY82, reliability is always a given.

Ready to Start Your Project?

From concept to completion, we're dedicated to delivering excellence in every detail. Get in touch with us and discover what we can do for you. Together, we'll bring your vision to life. Let's create something extraordinary.



SIXTY82

APAC	Malaysia
Australia	Mongolia
Azerbaijan	Myanmar
Bangladesh	Nepal
Belgium	New Caledonia
Bhutan	New Zealand
Brunei	Norway
Cambodia	Oman
Canada & USA	Pakistan
China	Papua New Guinea
Croatia	Philippines
Denmark	Portugal
Estonia	Russia
Finland	Saudi Arabia
France	Serbia
Germany	Singapore
Greece, Cyprus	South Korea
Hungary	Spain
Hong Kong	Sri Lanka
India	Sweden
Indonesia	Switzerland
Ireland	Taiwan
Italy	Thailand
Japan	The Netherlands
Kazachstan	Turkey
Laos	Ukraine
Luxembourg	United Arab Emirates
Latvia	United Kingdom
Lithuania	Vietnam
Macau	



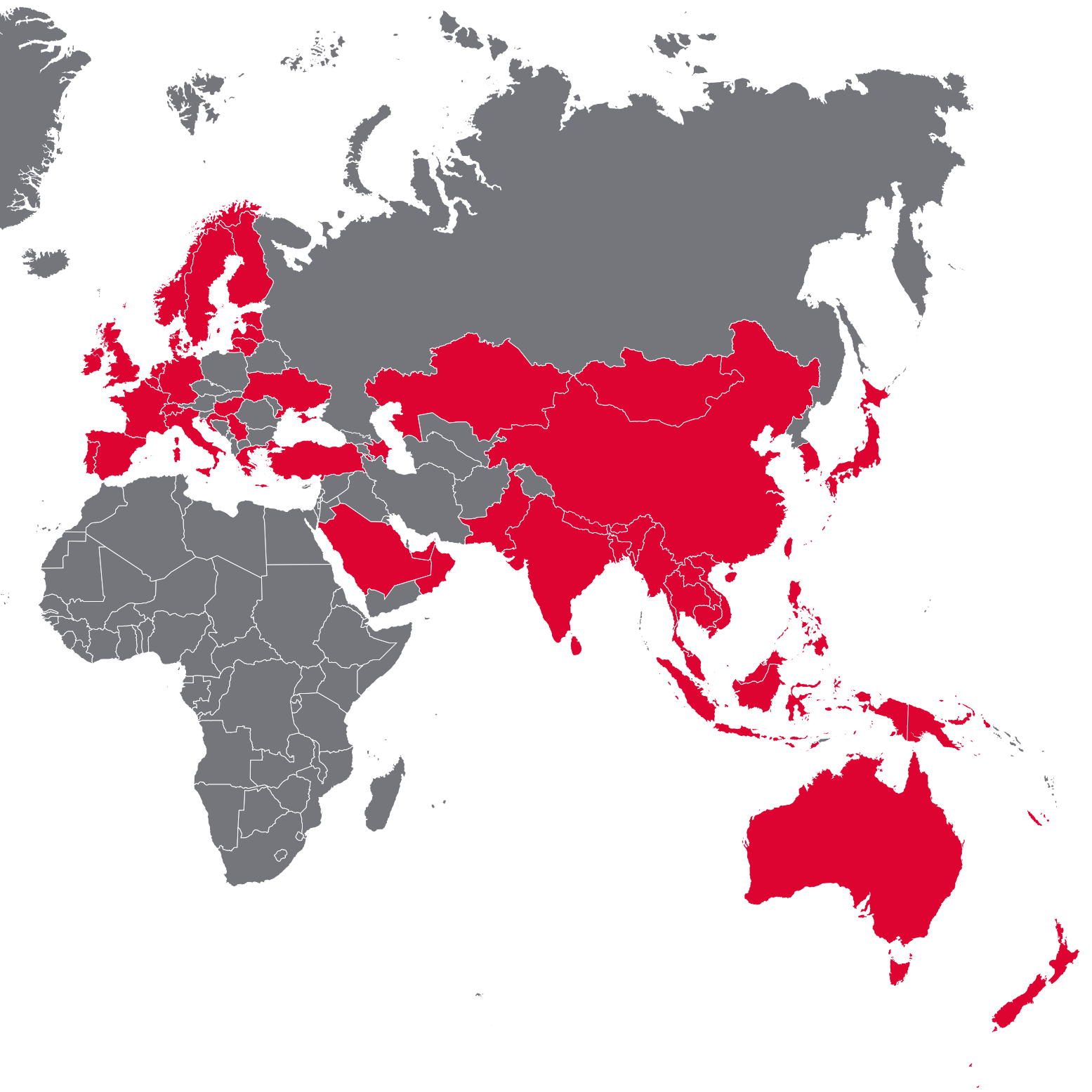

Official SIXTY82 offices

SIXTY82-NL Headquarters

Ampèrelaan 9
9207 AM Drachten
The Netherlands

Phone: +31 88 13 422 00
Email: info@SIXTY82.nl

APAC

SIXTY82 Doughty Asia

Lot 59-1, Jalan 51/205
46050, Petaling Jaya, Selangor
Phone: +603 7781 3357/3552
Mail: info@sixty82-doughty.com

Japan

SIXTY82 Doughty Japan

332-0012 埼圖県 농윳悉磊裁1-15-7
Honcho, Kawaguchi Shi,
Saitama 332-0012 Japan
Phone: +81 3 6912 9720

Please inform our website for
the latest updates about our
distribution network

Network

Azerbaijan

Mediatech LLC

Salamzade str. 2D
AZ1078
Bakoe
Phone: +994 124 347 856
Mail: ofiice@mediatech.az

Belgium

BV SOMPI 2.0

Steenweg 582
9470 Denderleeuw BE
Phone: +32 477 63 00 14
Mail: info@sompi.be

Canada & USA

Theatrixx Technologies

1655 Richardson, H3K 3J7
Montreal, Cuébec
Phone: +1 514 933 0077
Mail: info@theatrixx.com

Croatia

Perinic Sistemi

Vrhovec 28,
10000, Zagreb
Phone: +3 85 1 3778 283
Mail: vinko@perinic-sistemi.hr

Denmark

European Tour Production ApS

Stamholmen 93
2560 Hvidovre
Phone: +45 3630 7080
Mail: sixty82@etp.nu

Estonia

Progear OÜ

Artelli 19
EE-10127
Tallinn
Phone: +372 6728 280
Mail: progear@progear.ee

Finland

Electro Waves Oy

Headoffice
Ruukintie 2
02330 Espoo
Phone: +20 1200 100
Mail: info@electrowaves.fi

France

Axente

1, all.e d'Effiat,
91160 Longjumeau
Phone: +33 1691 05076
Mail: sixty82@axente.fr

Germany

Avenion GmbH

Wickerer Weg 26
65719 Hofheim
Phone: +49 6192 962 818 90
Mail: sixty82@avenion.de

CAST C.ADOLPH & RST DISTRIBUTION

Official competence centre

Kabeler Str. 54a
D-58099 Hagen
Phone: +49 2331 691500
Mail: mail@castinfo.de

Edelmat. GmbH

Veranstaltungstechnik

Eichborndamm 167, Geb.ude 55
13403 Berlin
Phone: +49 3076 7373200
Mail: SIXTY82@edelmat.de

MH-Lights®, Dipl.-Kfm. Martin Huber

Gusso-Reuss-Str. 4
82296 Schöengeising
Phone: +49-(0)8141-44154
Mail: info@mhlights.de

BTH.GbR

Auf dem Kalköfele 5
89597 Munderkingen
Phone: +49 7393 4081440
Mail: SIXTY82@BTHG.de

Rigging Plus GmbH

Werner-Otto-Straße 26
22179 Hamburg
Phone: +49 40 6085 0065
Mail: info@riggingplus.com

Greece, Cyprus

Omikron Electronics

Dervenion 31 & Posidonos
14451, Metamorfofi Attica
Phone: +30 211 3009200
Mail: info@omikron.gr

Hungary

DP Music

Gy.r u.2.
H-2040-Buda.rs
Phone: +36 2388 6980
Mail: info@dpmusic.hu

Ireland

A.C. Entertainment Technologies Ireland Ltd.

Coliemore House, Coliemore Road,
Dalkey, Dublin
Phone: +3538 7460 0202
Mail: sales@ac-et.ie

Italy

Audiosales s.r.l.

Via Ugo Bianchi 23
43058 Sorbolo (PR)
Phone: +39 0521 690290
Mail: info@audiosales.it

Jordan

Extreme Productions

39 Dejlal Street
Um Uthaina
Amman
Phone: +962 6 553 0322
Mail: info@extreme-productions.com

Kazachstan

AMEG Group

Yanushkevich 7/2
010000
Astana
Phone: +7 701 344 44 33
Mail: info@ameg.kz

Latvia

JSA Europe / Stage Company

Headoffice

Lielirbes iela 1, office B- 212
Riga LV-1046
Phone: +37 1277 74848
Mail: welcome@jsa-stage.company

Lithuania

Scenos Techninis Servisas

Aukštaičių str. 6
11341 Vilnius
Phone: +37 0527 52219
Mail: mail@sts.lt

Luxembourg

Codex Events S.A.

36, rue d'Oetrangle
L-5411 Canach
Phone: +35 2264 83333
Mail: info@codex.lu

Norway

First Audio

Haavard Martinsens vei 19 A
0978 Oslo
Phone: +47 4000 5166
Mail: info@firstaudio.no

Oman

J&C Joel Ltd.

Dubai Investments Park,
Warehouse 12-13
Dubai, UAE
Phone: +971 4884 7801
Mail: menasales@jcjoel.com

Portugal

SET2STAGE

Rua Gomes de Amorim n. 1158,
4490-091 - P.voa de Varzim
Phone: +35 1910 271125
Mail: marcosdematos@set2stage.pt

Saudi Arabia

J&C Joel Ltd.

Dubai Investments Park,
Warehouse 12-13
Dubai, UAE
Phone: +971 4884 7801
Mail: menasales@jcjoel.com

Serbia

PSP Elektronik

Bulevar Jovana Ducica 39
21000 Novi, Serbian
Phone: +381 21 520 907
Mail: office@psp.co.rs

Spain

Stonex

Cuclillo Street 5
28019 Madrid
Phone: +34 9142 81050
Mail: stonex@stonexsl.com

Sweden

Electro Waves Oy filial Sverige

Åkerby 4
645 94 Strängnäs
Phone: +46 070 7311444
Mail: info@electrowaves.eu

Switzerland

CAST

Route de Chavalon Z.I. C 77
1844 Villeneuve VD
Phone: +41 2196 56000
Mail: mail@castinfo.ch

The Netherlands

DANKQ

Ampèrelaan 9
9207 AM Drachten
Phone: +31 85 303 71 45
Mail: sales@dankq.nl

Moonbears

Zinkstraat 9
4823 AD Breda
Phone: +31 76 587 23 95
Mail: hello@moonbears.eu

SENCI

Nijverheidsweg 20
7671 DA Vriezenveen
Phone: +31 8530 36597
Mail: info@senci.nl

Turkey

Modern Elektronik A.Ş.

Aydın Sok. No. 10
34340
Beşiktaş, İstanbul
Phone: +90 (212) 385 47 47
Mail: info@modern.com.tr

Ukraine

JSA Europe / Stage Company

Yevhena Konovaltsia st. 103
office 414 L'viv, 79000
Phone: +38 0443 614848
Mail: welcome@jsa-stage.com

UAE

J&C Joel Ltd.

Dubai Investments Park,
Warehouse 12-13
Dubai, UAE
Phone: +971 4884 7801
Mail: menasales@jcjoel.com

United Kingdom

A.C. Entertainment Technologies Headoffice

Centauri House, Hillbottom Road,
High Wycombe, Buckinghamshire.
HP12 4HQ
Phone: +44 1494 446000
Mail: sixty82@ac-et.com

A.C. Entertainment Technologies Leeds Office (Northern UK Sales)

Hawksworth Commercial Centre,
Elder Road, Leeds, West Yorkshire.
LS13 4AT
Phone: +44 1132 557666
Mail: sixty82@ac-et.com

Production Park

5 Langthwaite Road
Langthwaite Business Park
South Kirkby, Wakefield
West Yorkshire WF9 3AP
Mail: info@sixty82.nl

Credits

Author: Rainier Smeding

Catalogue design: Tieme Dekker

With contributions from NL, FR and UK with love

PVersion: V25.1

© 2025 SIXTY82, Drachten NL

All rights reserved. No part of this publication may be reproduced in any manner without permission.

The information in this catalogue is subject to printing mistakes and/or product modifications.

All colour printings are to be regarded as an indication and may be changed at any time depending on production necessities.

 <https://www.facebook.com/SIXTY82>

 www.SIXTY82.nl



SIXTY82™

Sixty82 BV

Ampèrelaan 9 | 9207 AM Drachten | The Netherlands

+31 88 13 422 00

info@sixty82.nl

www.sixty82.nl

The Innovators